

Digitales Video

SS 2019

Olaf Krafft

Medien und Informationszentrum/Leiter AVM-Service/Gebäude 7

- Was müsst ihr über **Digitales Video** wissen?
- Was kann ich euch vermitteln?
- Viele Informationen müsst ihr immer wieder aktualisieren?

- Wo erscheinen Videos?
- Wer produziert sie?
- Welche Mittel (Kamera, Schnitt...) werden eingesetzt?
- Wo werden sie veröffentlicht?
- Welche Zwecke verfolgen sie – Kultur, Werbung...?
- Welche kulturellen Veränderungen lassen sich erkennen?

und was soll das...

<https://www.tagesschau.de/inland/youtube-akk-101.html>

Reaktion auf ein youtube Video.

Die CDU entfernt Youtube-Videos von ARD und ZDF. Nico Semsrott von Die PARTEI macht ARD und ZDF darauf aufmerksam.

Kurz vor den Europa-Wahlen 2019 ist die CDU erneut in die Kritik geraten. Nico Semsrott, Spitzenkandidat der Satirepartei die PARTEI und bekannt als Satiriker aus der "heute show" bemerkte, dass der Youtube-Kanal der CDU (cdutv) massenhaft angereichert war mit Mitschnitten aus öffentlich-rechtlichen Sendern.



Blade Runner 2049 • release date 2017



Blade Runner • release date 1982

A cinematic title card from the movie Blade Runner. The scene is set in a dark, industrial interior with a large window in the background showing a bright, hazy sun. The floor is highly reflective, mirroring the scene above. In the center, a person is walking away from the camera towards the window. The text "LOS ANGELES <2019>" is superimposed in the lower center in a glowing, cyan, monospace font.

LOS ANGELES <2019>

Was hat sich in den 35 Jahren
seit 1982 geändert?

Kamera

AufnahmeFormat

Projektionsmedium

Die Kamera 1982

Panavision Panaflex Gold • 35 und 70mm Film

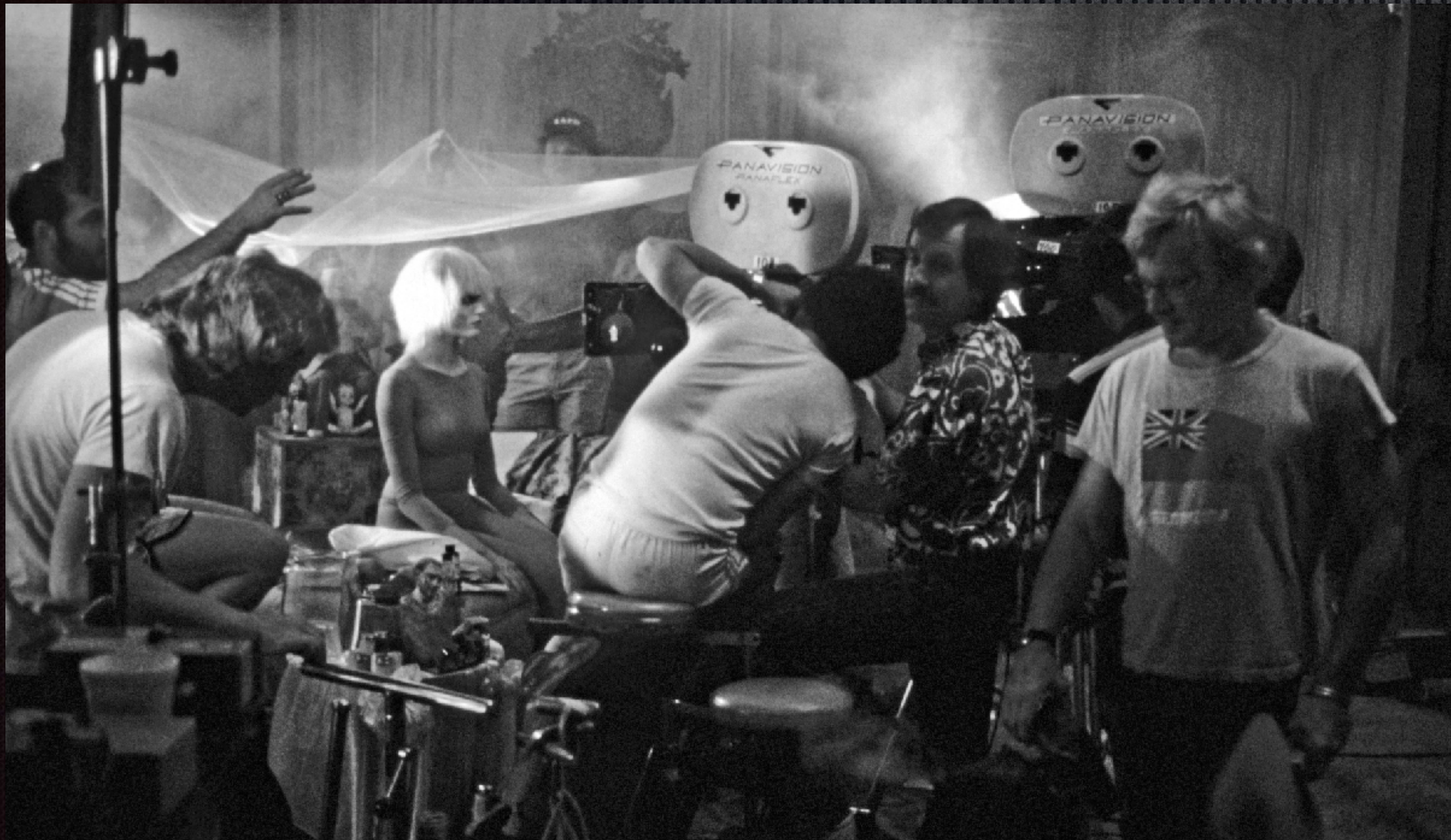

Die Kamera 2017

Arri Alexa Mini • Arri Alexa Plus • Arri Alexa XT Studio



ARRIRAW
(3.4K)
(2.8K)
digital

Filmschnitt

Film Schneidetisch

Digitale Software



Kinoprojektion

35mm Projektor



Digital-Projektor



Was hat sich in den letzten Jahren im Bereich
Digitales Video
verändert?

Aufnahmetechnik



Editing



Distribution



NETFLIX

Aufnahmetechnik

- Hardware- Vielfalt
- 4K
- hohe Qualität für jeden “Geldbeutel”

Editing

- schneller
- professioneller
- noch günstiger

Distribution

- LIVE-Streaming
- überall verfügbar
- Finanzierung über Werbung

- ★ Video-on-demand (Netflix & Co)
- ★ Mediatheken
- ★ youtube (seit 2005)
- ★ Qualität der Inhalte?
- ★ Qualität der Bilder?
- ★ Videos mit dem Smartphone herstellen
- ★ Videos mit dem Smartphone anschauen

4K Digital Cinema

← 4096 x 2160

2K →

2048 x 1080

1920 x 1080

1280 x 720

768 x 576

720p

576i

1080i

4K UltraHD

3840 x 2160

Pixel Auflösung

8K Resolution



Derú

SD

HD

4K

8K

7680×4320 pixel

360°

Explore the best 360 videos on Vimeo



360 Cinema
Immerse yourself in beautiful 360 video, hand-picked by Vimeo. Stream it all in glorious 4K Ultra HD.

[+ Follow](#)



Pony Pony Run Run - Alrig... 360
Mackenzie Sheppard | 4880 plays

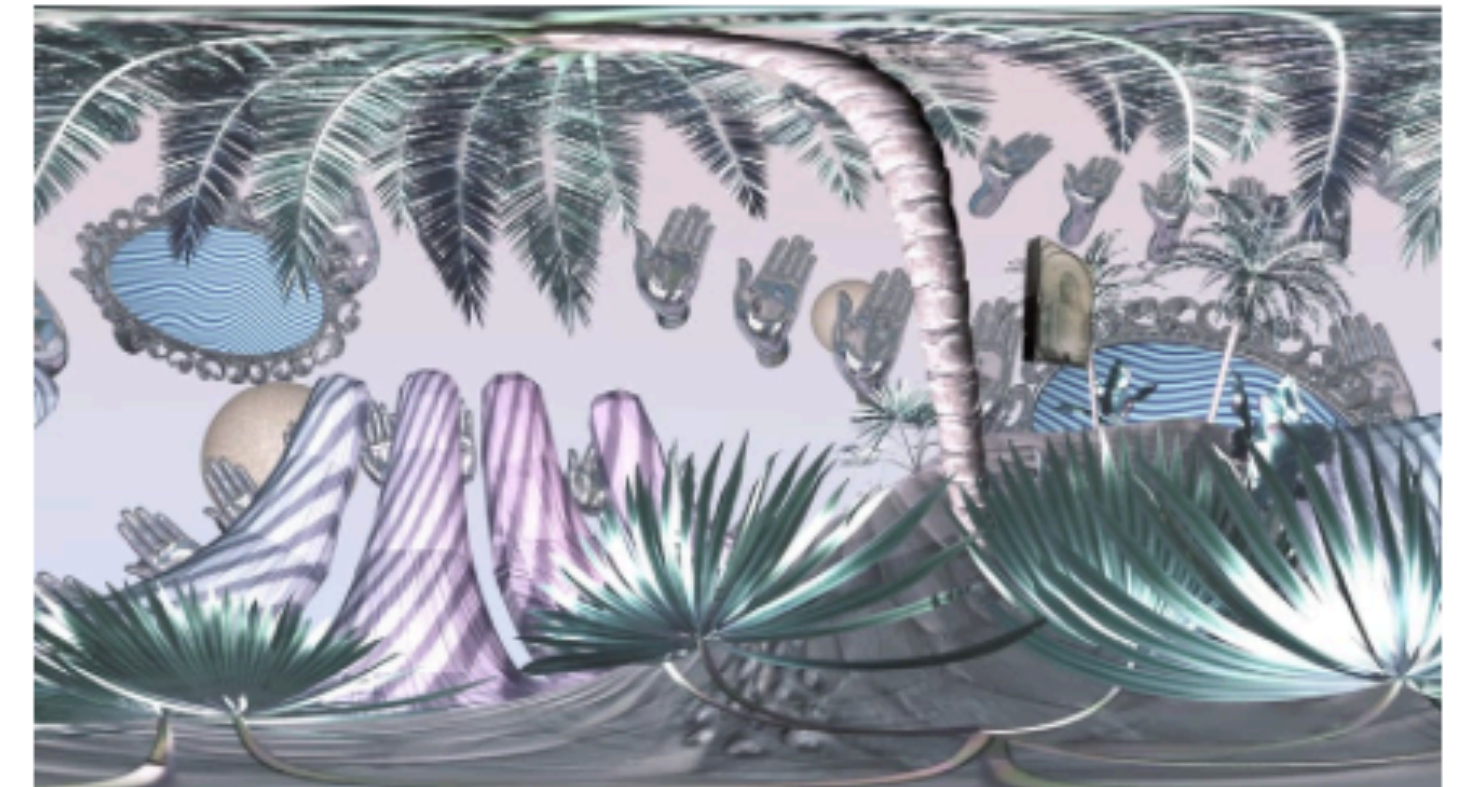

- I t ' s A l r i g h t ツ 360
baron lanteigne | 3336 plays

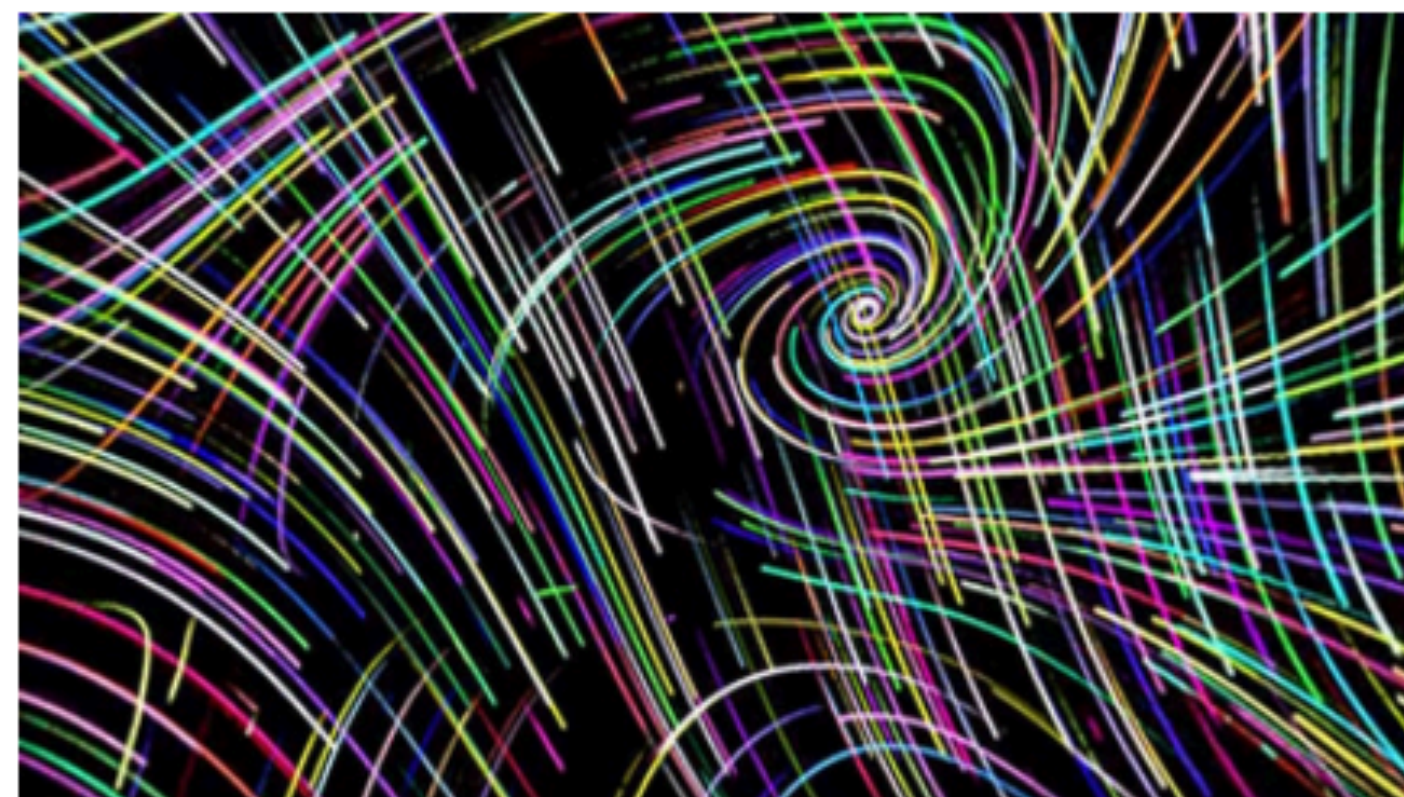

Evidence Of Existance - A ... 360
Hector Santizo | 3855 plays



HELVETIA BY NIGHT 360° 360
Christian Mülhauser | 71.2K plays

360°

Kakao-Doku
aus Madagaskar



<https://www.zotter.at/de/das-ist-zotter/videos.html>

HDR (High Dynamic Range)

4K • HDR (High Dynamic Range)

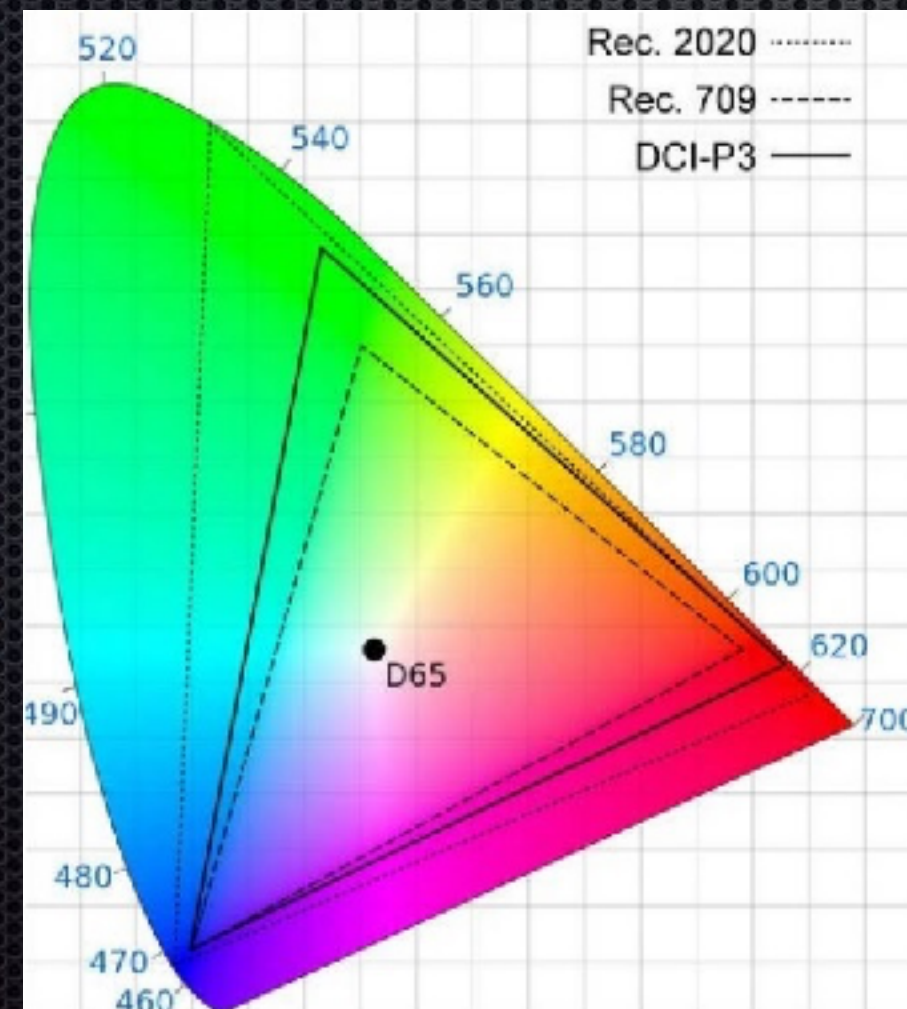

4K • HDR (High Dynamic Range)

Nits, contrast ratio and color gamut

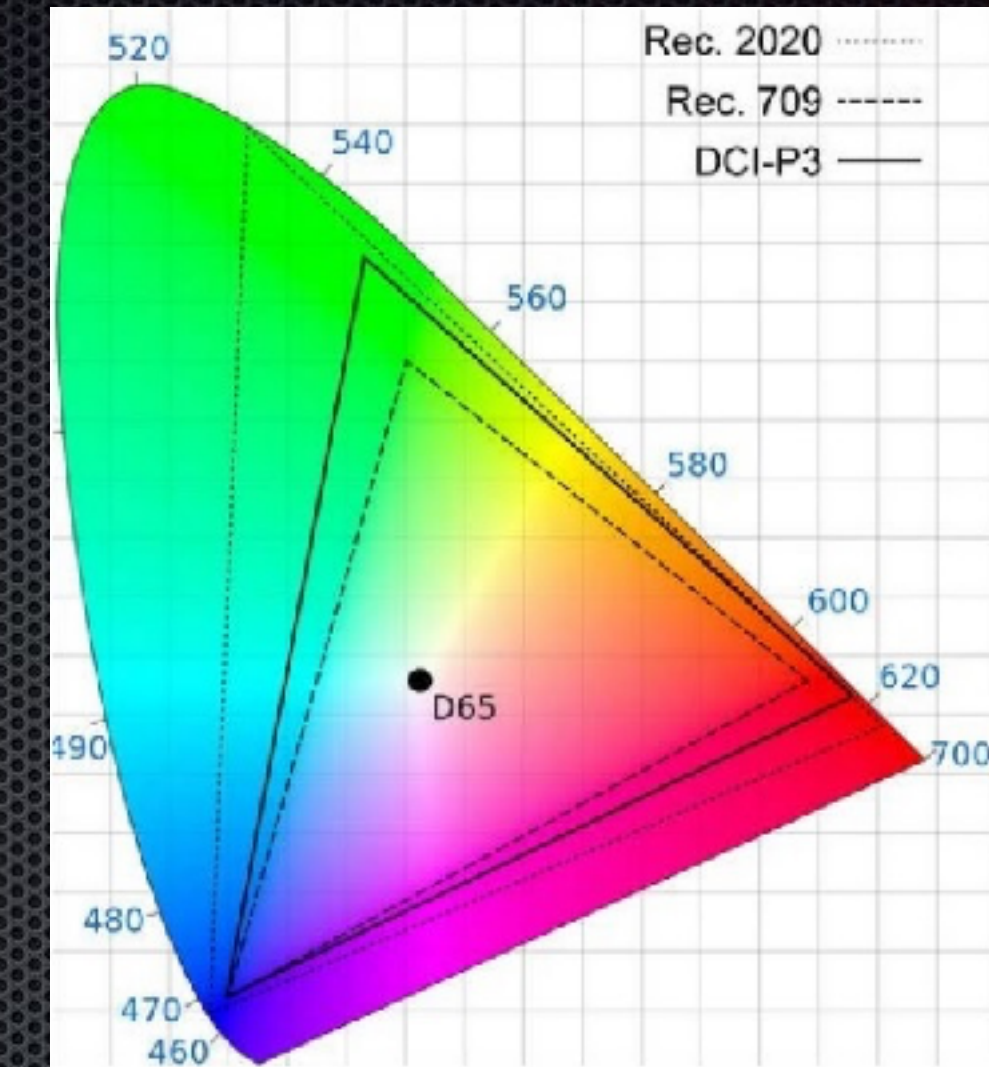

【 Original 】 Original-Quelle	【 SDR TV 】 Defizite in dunklen und hellen Bereichen	【 HDR TV 】 Zeigt Details, wie vom Filmmacher gewollt

© HDR : High Dynamic Range

Was ist wichtiger:
Form/Technik oder Inhalt?

Woran erkennen wir die inhaltliche Qualität?

Video im Internet

2001 • Live-Stream für Universal Music



480 x 360 Pixel, 76 kbit/sec für 56k-Modem
Andreas Scholl, Wigmore Hall, London 2001

Trailer 2014



HD, 4.190 kbit/sec • The Grand Budapest Hotel • Wes Anderson

Trailer 2014

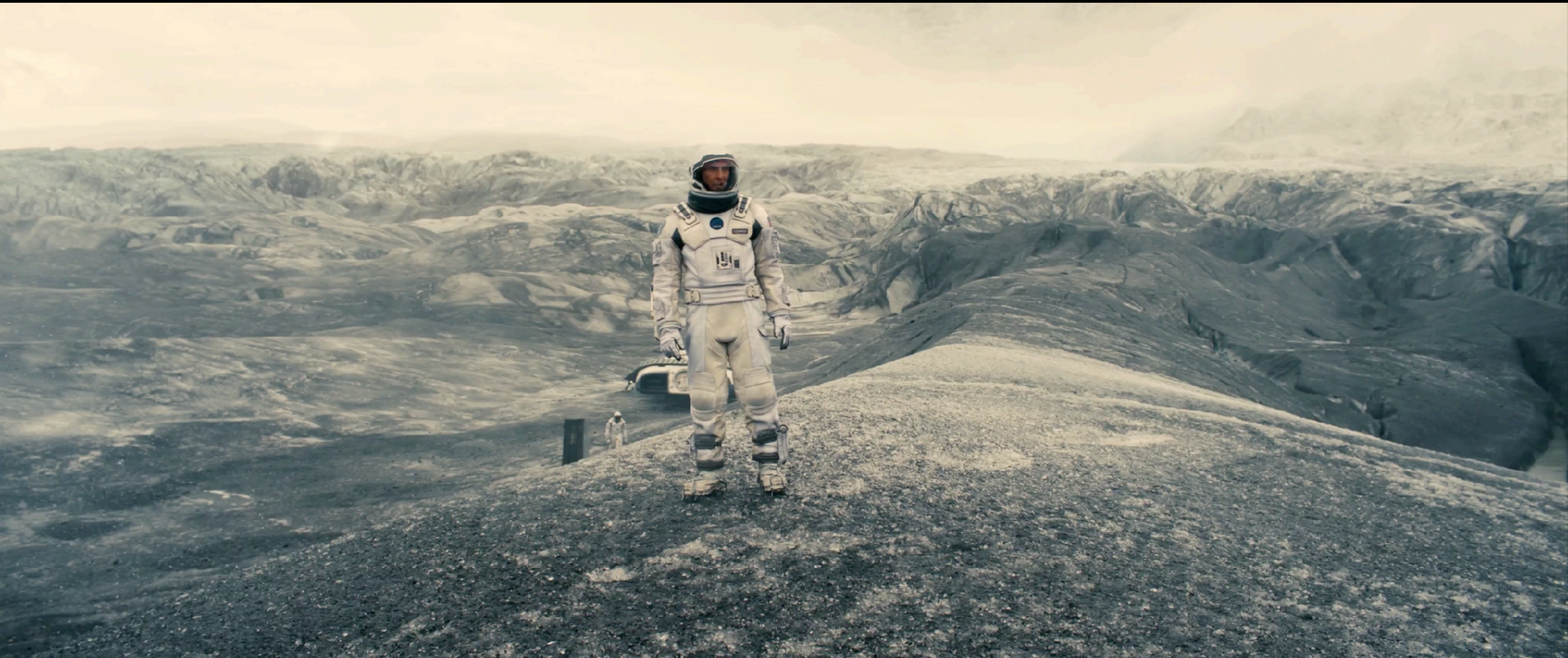

4K • 4096 x 1716 • 36.207 kbit/sec • Interstellar • Christopher Nolan

Trailer 2014

MATTHEW
McCONAUGHEY

ANNE
HATHAWAY

JESSICA
CHASTAIN

MICHAEL
AND
CAINE



- ★ 476 fache Datenrate im Vergleich zum Andreas Scholl Video von 2001
- ★ Trailer hat höhere Qualität(4K) als der Film im Kino (2K)

A FILM BY CHRISTOPHER NOLAN

INTERSTELLAR

THE END OF EARTH WILL NOT BE THE END OF US.

WARNER BROS. PICTURES AND PARAMOUNT PICTURES PRESENT
IN ASSOCIATION WITH LEGENDARY PICTURES A SYNCOPY/LYNDA OBST PRODUCTIONS PRODUCTION A FILM BY CHRISTOPHER NOLAN "INTERSTELLAR"
MATTHEW McCONAUGHEY ANNE HATHAWAY JESSICA CHASTAIN BILL IRWIN ELLEN BURSTYN AND MICHAEL CAINE COSTUMES BY MARY ZOPHRES
MUSIC BY HANS ZIMMER EDITOR LEE SMITH, A.C.E. PRODUCTION DESIGNER NATHAN CROWLEY DIRECTOR OF PHOTOGRAPHY HOYTE VAN HOYTEMA, F.S.P., N.S.C.
EXECUTIVE PRODUCERS JORDAN GOLDBERG JAKE MYERS KIP THORNE THOMAS TULL WRITERS JONATHAN NOLAN AND CHRISTOPHER NOLAN
PRODUCED BY EMMA THOMAS CHRISTOPHER NOLAN LYNDA OBST DIRECTED BY CHRISTOPHER NOLAN



LEGENDARY



twitter.com/InterstellarUK

NOVEMBER 7
2014

facebook.com/Interstellarmovie



Was nützt uns die hohe Auflösung?

4096 x 1716



2880 x 1800



1280 x 800





aktuell



Die Lebenslaute Soli-DVD kann in unserem [Shop](#) ab sofort bestellt werden!

WIR WOLLEN EURE KRIEGE NICHT - Protest gegen Bundeswehr auf Hafengeburtstag



06.05.2017 Jedes Jahr zum Hamburger Hafengeburtstag präsentiert die Bundeswehr sich mit Kriegsgerät "zum Anfassen". In diesem Jahr konnte die "BONN" von Interessierten im Rahmen der Open Boat besichtigt werden. Das Bündnis "BoB - Bildung ohne Bundeswehr" protestierte gegen diese Zurschaustellung. Die Militärpolizei versuchte diesen Protest gewaltsam zu unterbinden.

Den Film im HTML5-Player anzeigen. (mp4: 21,69 MB)

Als Flash - Video anschauen. (21,69 MB)

Als Video (mp4) herunterladen. (21,69 MB)

Über uns

[Kontakt](#)
[Selbstverständnis](#)
[Impressum](#)
[Ausstellung und Screenings](#)
[Kleiner Guide zur Medien-Koordination](#)
[Haftungsausschluss](#)
[Gästebuch](#)
[Solishop](#)

graswurzel.tv im Social Web

[@graswurzel_tv](#) folgen

3.101 Follower

Tweets by [@graswurzel_tv](#)

[graswurzel.tv](#)

www.graswurzel.tv

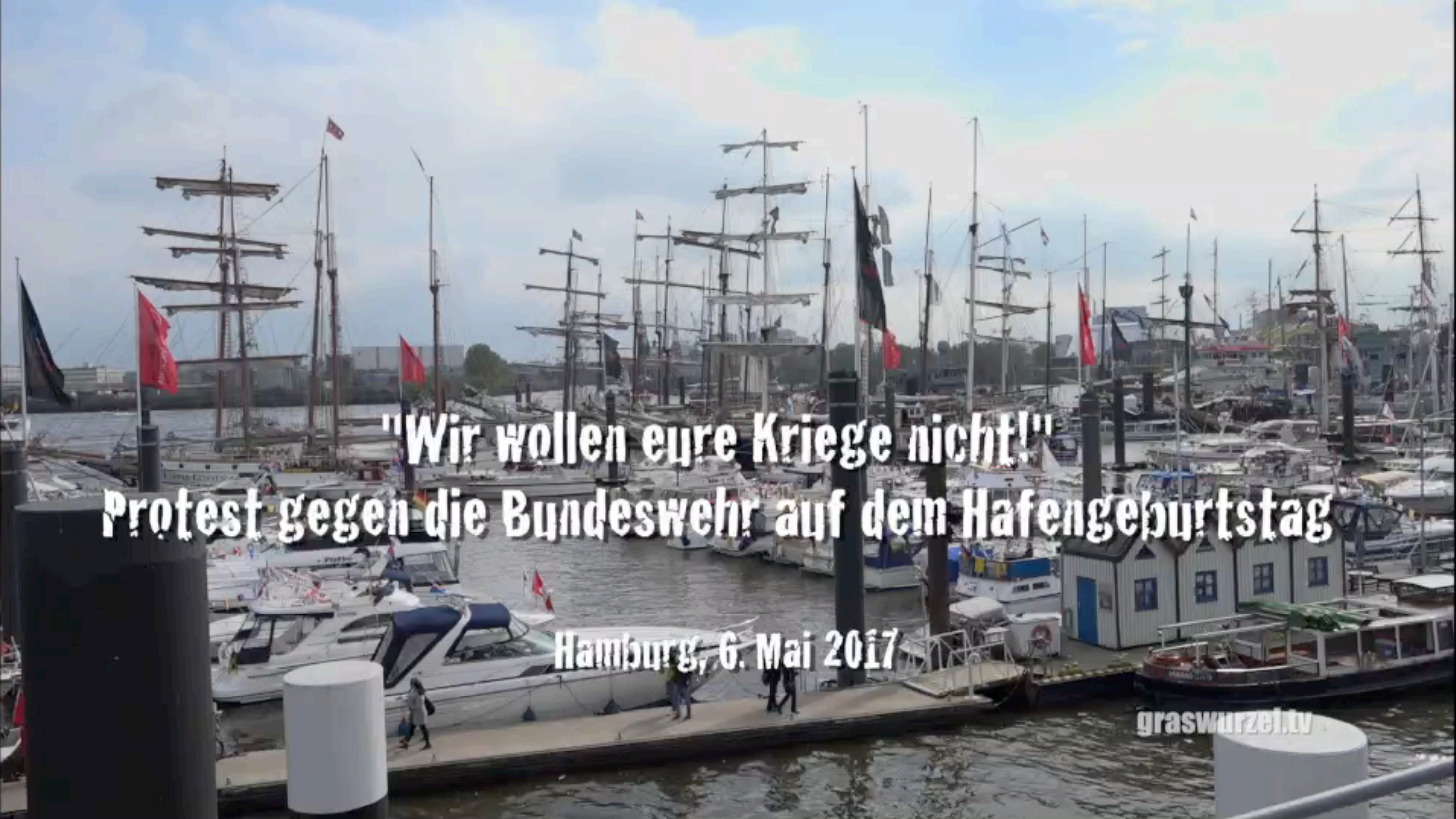

"Wir wollen eure Kriege nicht!"
Protest gegen die Bundeswehr auf dem Hafengeburtstag

Hamburg, 6. Mai 2017

graswurzel.tv



Legacy Warnings!

*Von Katja Becker, Jean-Jacques Schwenzfeier
& Jonathan Happ*

[09.04.2015] Südafrika steht am Scheideweg. Millionen Menschen verfügen über keinen Strom. 85 % des Stroms werden mit dreckiger Kohle produziert. Die globale

Klimaerwärmung zwingt zur Veränderung. Deutsche Technologien könnten helfen, das Land zum Vorreiter der regenerativen Energien zu machen. Doch mächtige Industrieinteressen würden lieber eine afrikanische Renaissance der Atomkraft sehen.

Derzeit arbeiten wir an einem Dokumentarfilm über die Energiepolitik Südafrikas und dem Nord-Süd-Techn... [weiterlesen](#) | Trailerwebseite: <http://www.ujuzi.de/legacywarnings>



www.expedition-nachhaltige-entwicklung.de

<http://www.ujuzi.de>

melawear.de - Fairtrade & Organic Clothing

Ist das Fernsehen tod ?

Gucken alle nur ins Internet /Computer ?

Ein Blick in die Geschichte...

Photographie

1826

1800

1900

2000

2017

Joseph Nicéphore Niépce
William Henry Fox Talbot
Louis Jacques Mandé
Daguerre



1826

1800

1900

2000

2017

Joseph Nicéphore Niépce

Ö l b e h a n d e l t e s
B i t u m e n

Blick aus dem Fenster in Le Gras



1829

1800

1900

2000

2017

Louis Jacques
Mandé Daguerre
D a g u e r r e o t y p i e
Boulevard in Paris, Südgalérie





1835

1800

1900

2000

2017

William Henry Fox Talbot
N e g a t i v

Erkerfenster in der Südgalerie von Lacock
Abbey

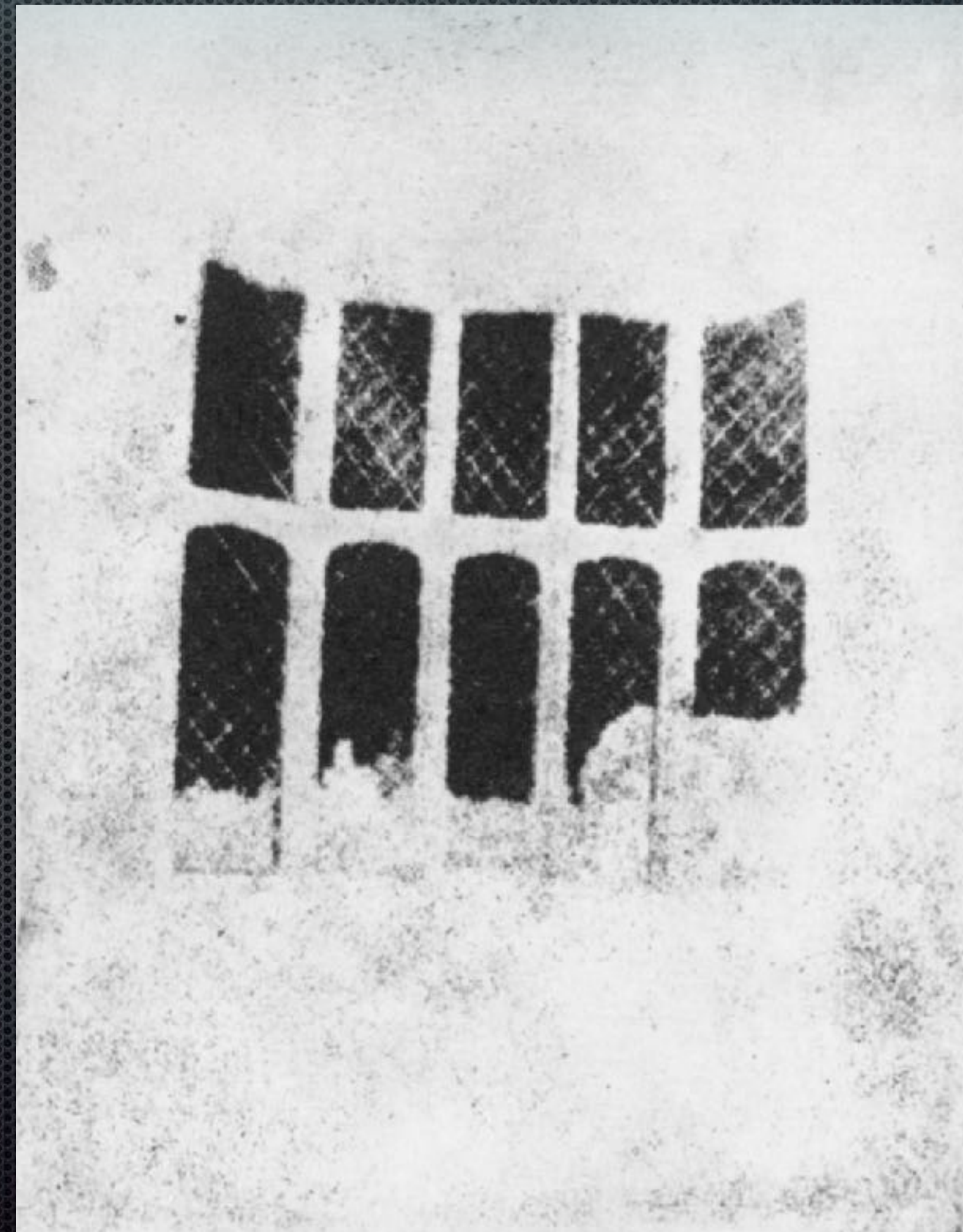

1878

1800

1900

2000

2017

Edward Muybridge

“The Horse in Motion”

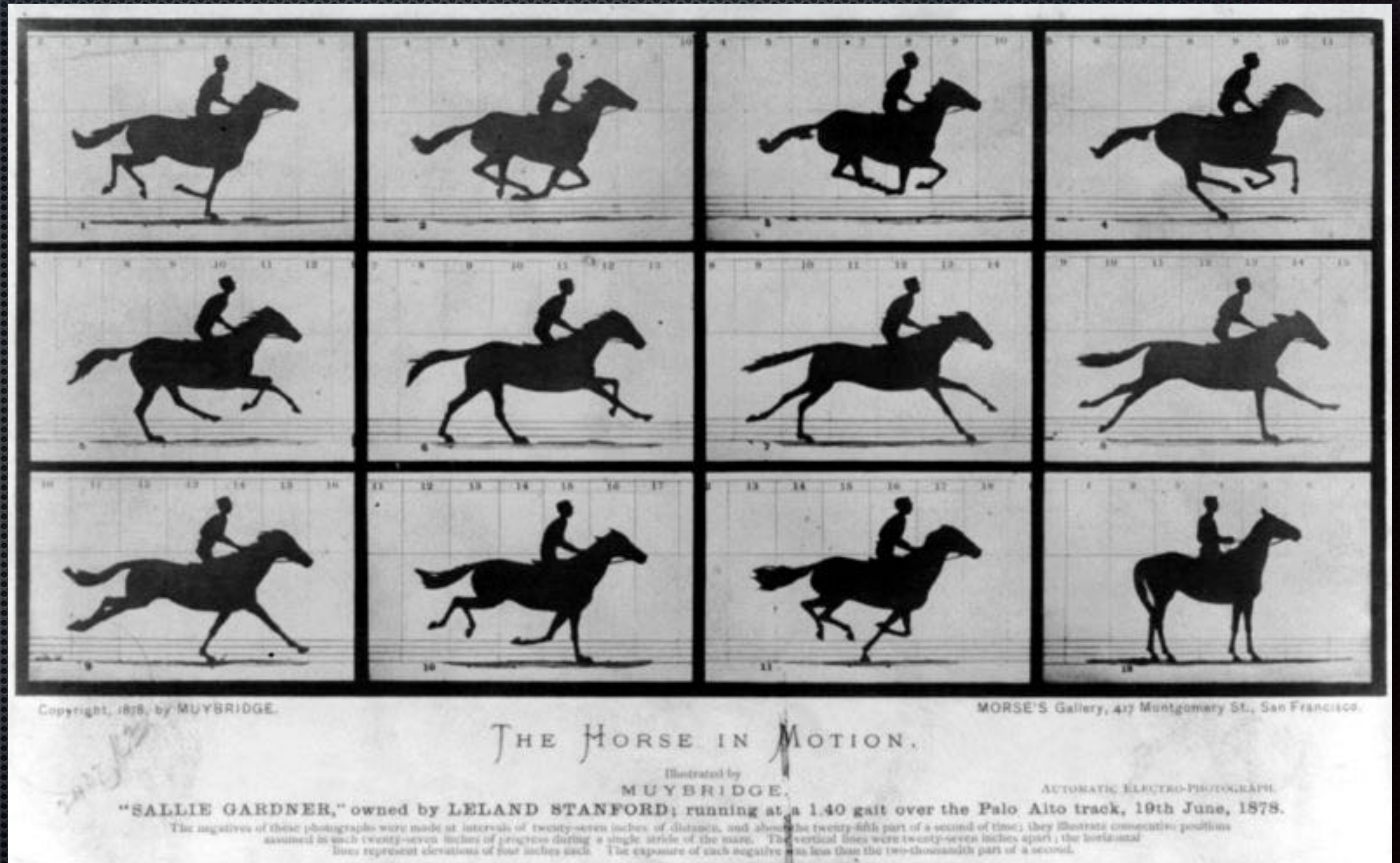

1878

1800

1900

2000

2017

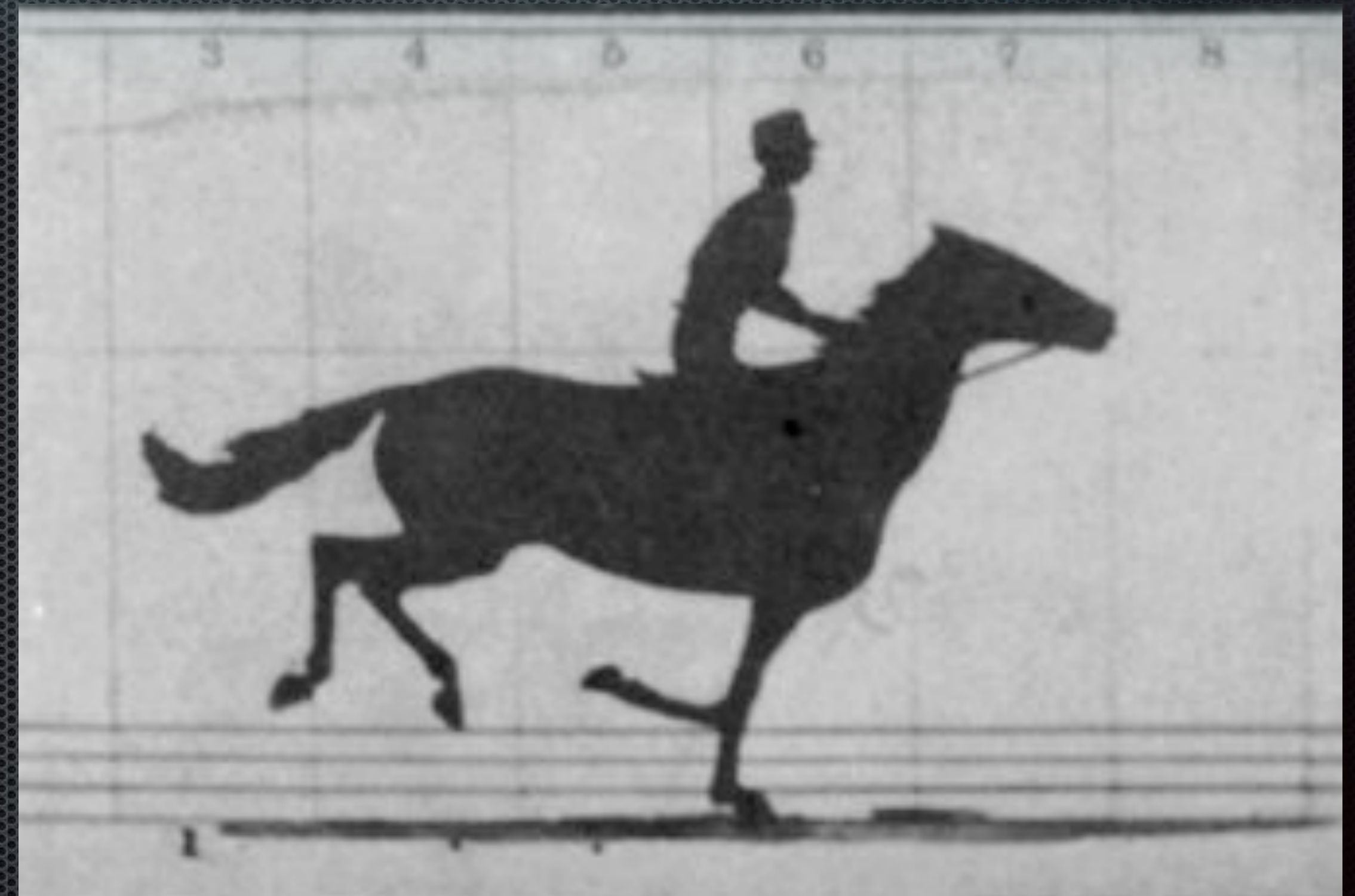

Edward Muybridge
12 Bilder pro Sekunde

1908

1800

1900

2000

2017

Albert Kahn





1908

1800

1900

2000

2017







Autochrome-Verfahren der Gebrüder Lumiere – 1907

1908

1800

1900

2000

2017

Albert Kahn



arte



1913 / 1934

1800

1900

2000

2017

Kleinbild-Film Typ 135

35mm-Film

1913 – Oskar Barnack

1934 – Kodak

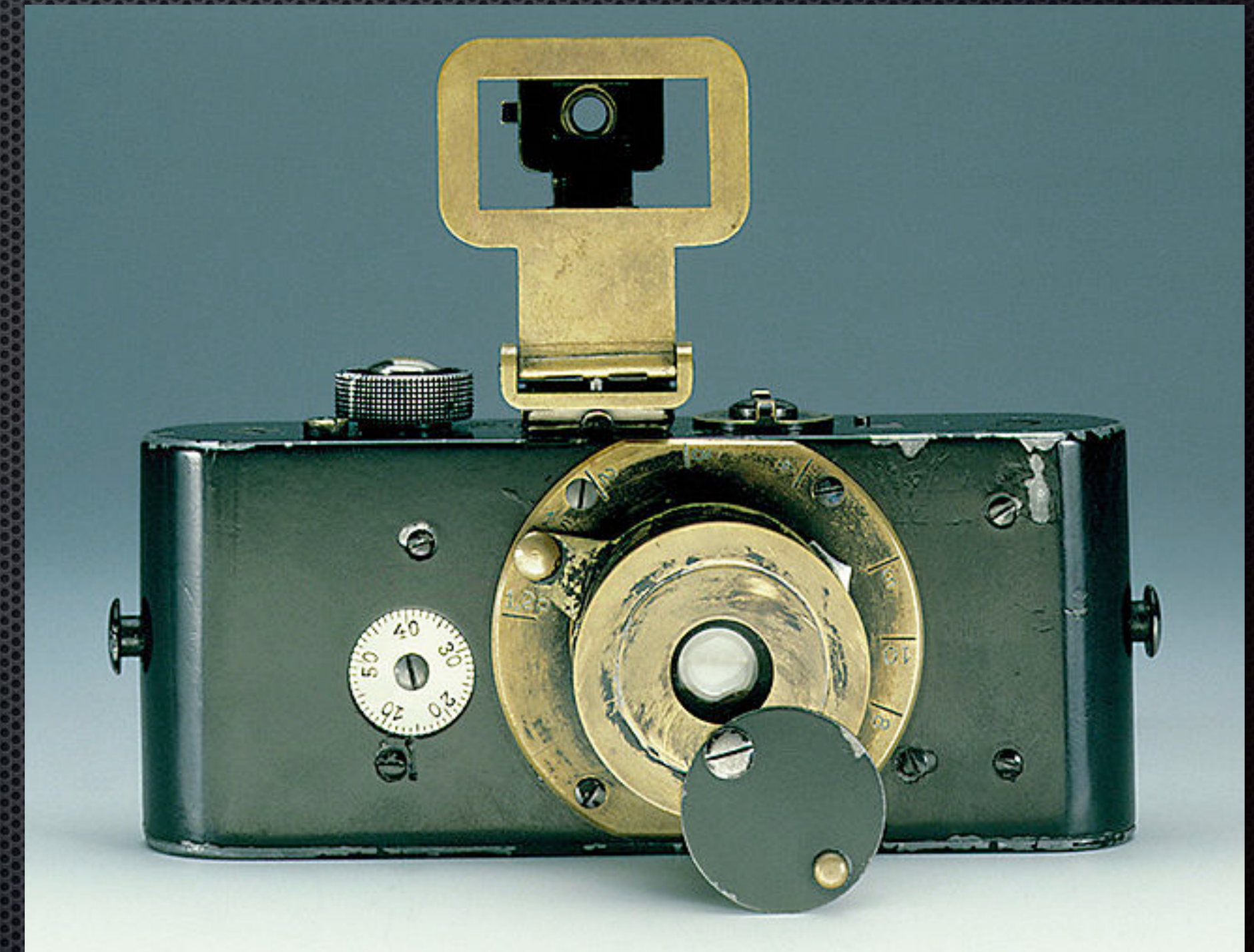

Ur-Leica 1913

1959

1800

1900

2000

2017

Nikon F

Single-lens reflex

(SLR)



1980

1800

1900

2000

2017

Nikon F3

1980 bis 2001



1948 bis 2016

1800

1900

2000

2017

Polaroid • Instant Film Camera



Land Camera 1948



SX 70 1972



Impossible I-1 2016

1972

1800

1900

2000

2017

Polaroids



Warhol Polaroids



Fashion Show



Robert Mapplethorpe

1972

1800

1900

2000

2017

Polaroids

20 x 24 cm

Positiv



1975

1800

1900

2000

2017

Digital Camera Prototype (Kodak) • 1975

Steven Sasson

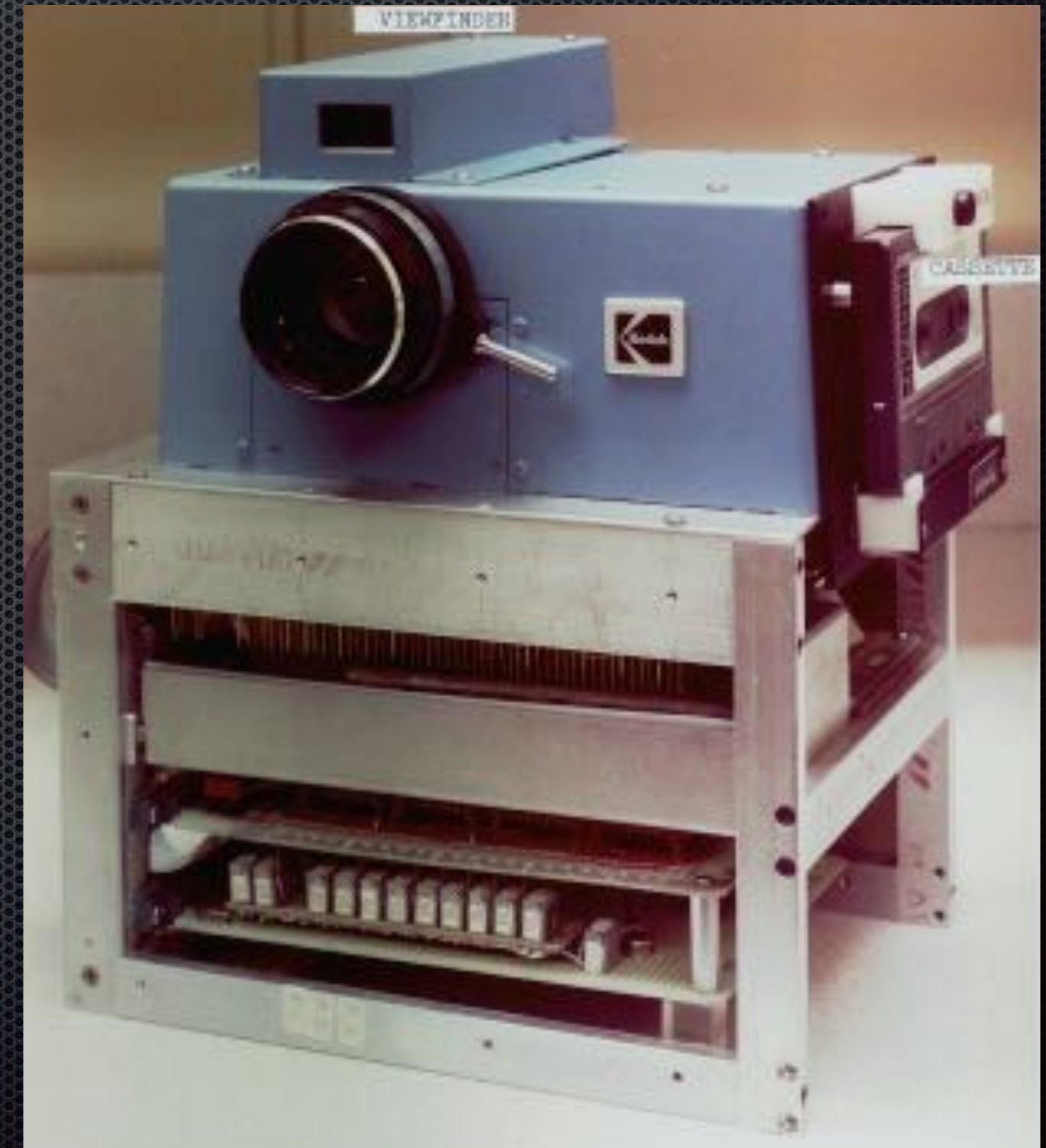

1981 bis 1998

1800

1900

2000

2017

Digital Camera



Sony mavica 1981



Kodak DC25
1996



Nikon D1 1998

2008

1800

1900

2000

2017

Canon 5D Mk II

HDSLR

High Definition single lens reflex

Full Frame 36 x 24 mm

Videoaufnahme in 1080p

“Filmlook”





Philip Bloom • Fotograf • 2009 • Canon 5D Mk II



“Kuba im Wandel der Zeit” • ZDF Reise-Doku • 2011 • Canon 5D Mk II

Exkurs: Monochrome Bilder

2012



Meßsucherkamera von Leica

18 MegaPixel monochrom CCD

Full Frame 36 x 24 mm

Nur Schwarz-Weiß Fotos

Preis ca. 6800 EUR



Leica M9 monochrom

MONOCHROME AND COLOUR SENSORS - A COMPARISON

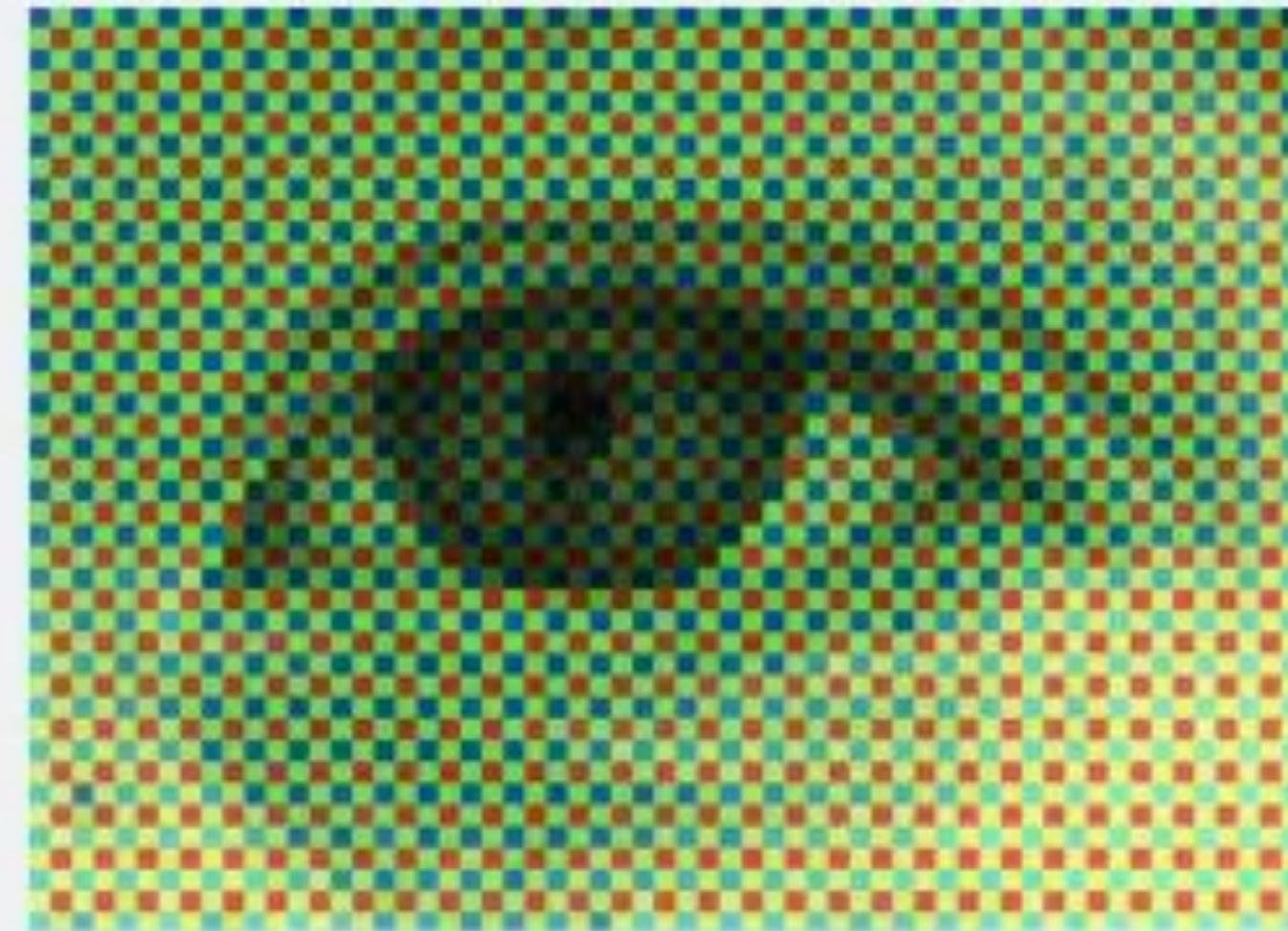
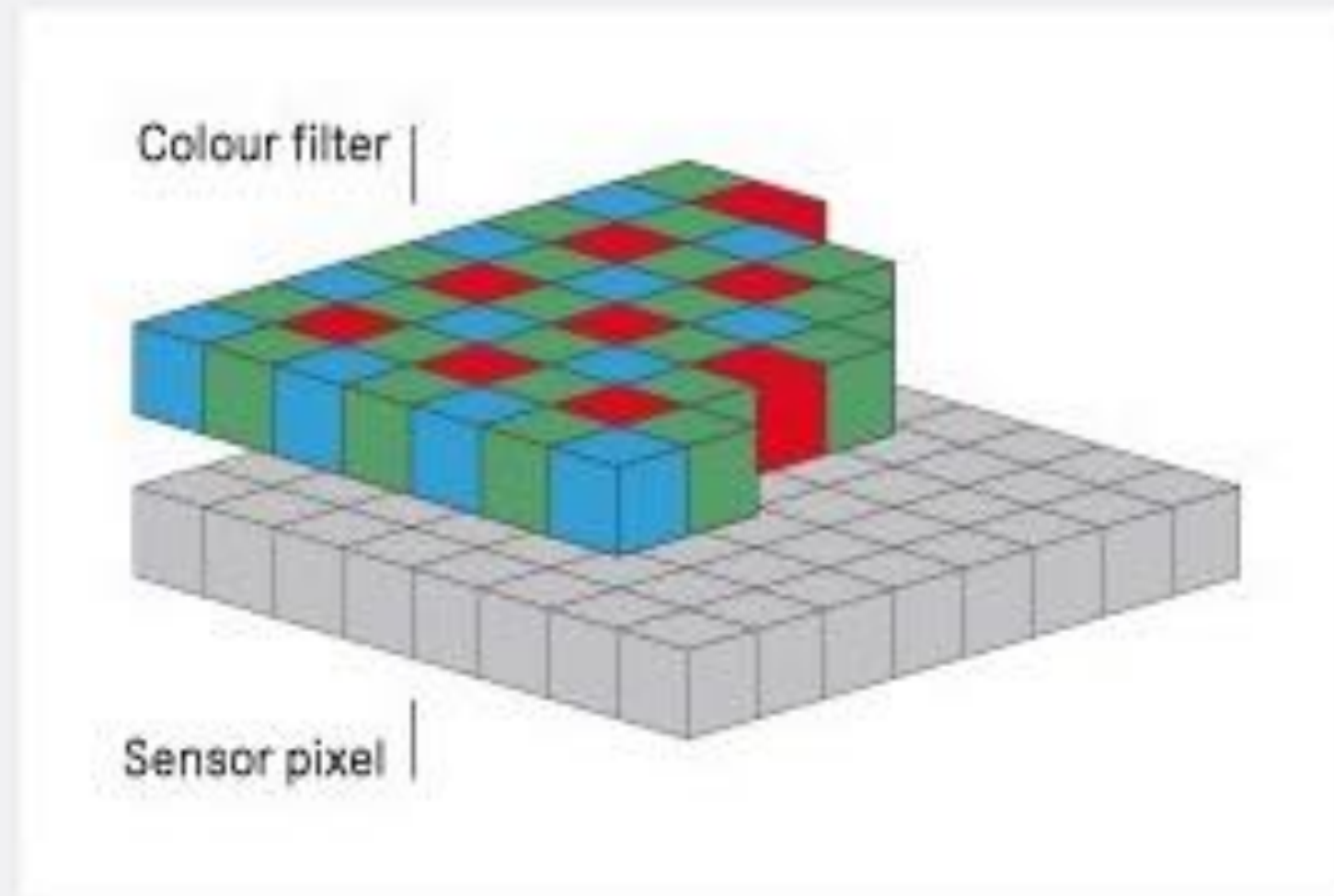

To let an image sensor 'see in colour', colour filters in the basic colours - red, green and blue - are allocated to individual pixels. However, before a visible image can be created, the colour information recorded by neighbouring pixels must be combined - an additive process that naturally reduces the native sharpness.

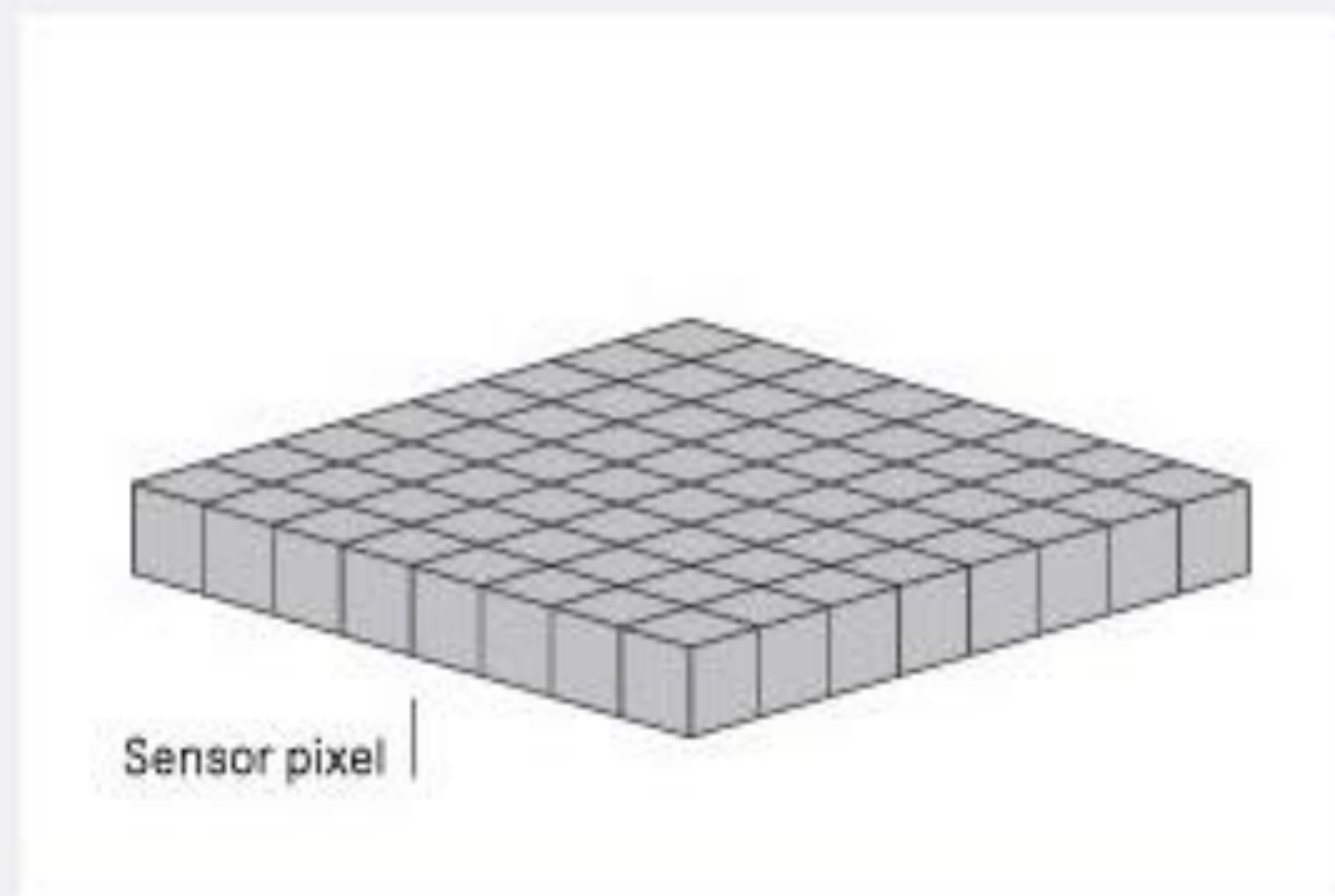

The sensor of the Leica M Monochrom is 'colour-blind'. In consequence, each individual pixel records true luminance values from which a genuinely monochrome image, characterised by a native and incomparable sharpness, can be created without any additional processing.



Jonathan Slack • Leica M9 monochrom • Fisherman • 2012



Adam Anselm "Moonrise", Hernandez, New Mexico, 1941

Schwarz-Weiß-Film

gedreht auf Arriflex Cameras

1986

"Three of the damnedest performances
in an eccentric ensemble since the Marx Brothers."
—Andrew Sarris, Village Voice



DOWN BY LAW

TOM WAITS · JOHN LURIE · ROBERTO BENIGNI
A NEW FILM BY JIM JARMUSCH

ISLAND PICTURES Presents A BLACK SNAKE GROKNERBERGER FILM PRODUCTION
DOWN BY LAW With TOM WAITS · JOHN LURIE · ROBERTO BENIGNI
Director of Photography ROBBY MÜLLER Music JOHN LURIE Songs by TOM WAITS Editor MELODY LONDON
Co-Producers TOM ROTHMAN · JIM STARK Executive Producers OTTO GROKNERBERGER · CARY BROKAW · RUSSELL SCHWARTZ
Producer ALAN KLEINBERG Written and Directed by JIM JARMUSCH

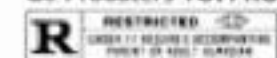

Kinofilm in schwarz-weiß
“Francis Ha” (2012)

gedreht auf Canon EOS 5D Mark II

Monochrome Videokameras
EPIC-M MONOCHROME (2012)

ARRI Alexa XT B+W (2012 ?)



Hollywoodfilm in schwarz-weiß
“Sin City” (2012)
gedreht auf Arri Alexa M

Monochrome Videokameras
EPIC-M MONOCHROME (2012)

ARRI Alexa XT B+W (2012 ?)



Film



Arrivee d'un train en gare à La Ciotat (1895) • Auguste und Louis Lumière

Die ersten öffentlichen Aufführungen

11. November 1895

Die Gebrüder Skladanowski
im Berliner Varieté Wintergarten

28. Dezember 1895

Die Gebrüder Lumière
Untergeschoß des Pariser Grand Café die erste
Vorführungen vor zahlendem Publikum

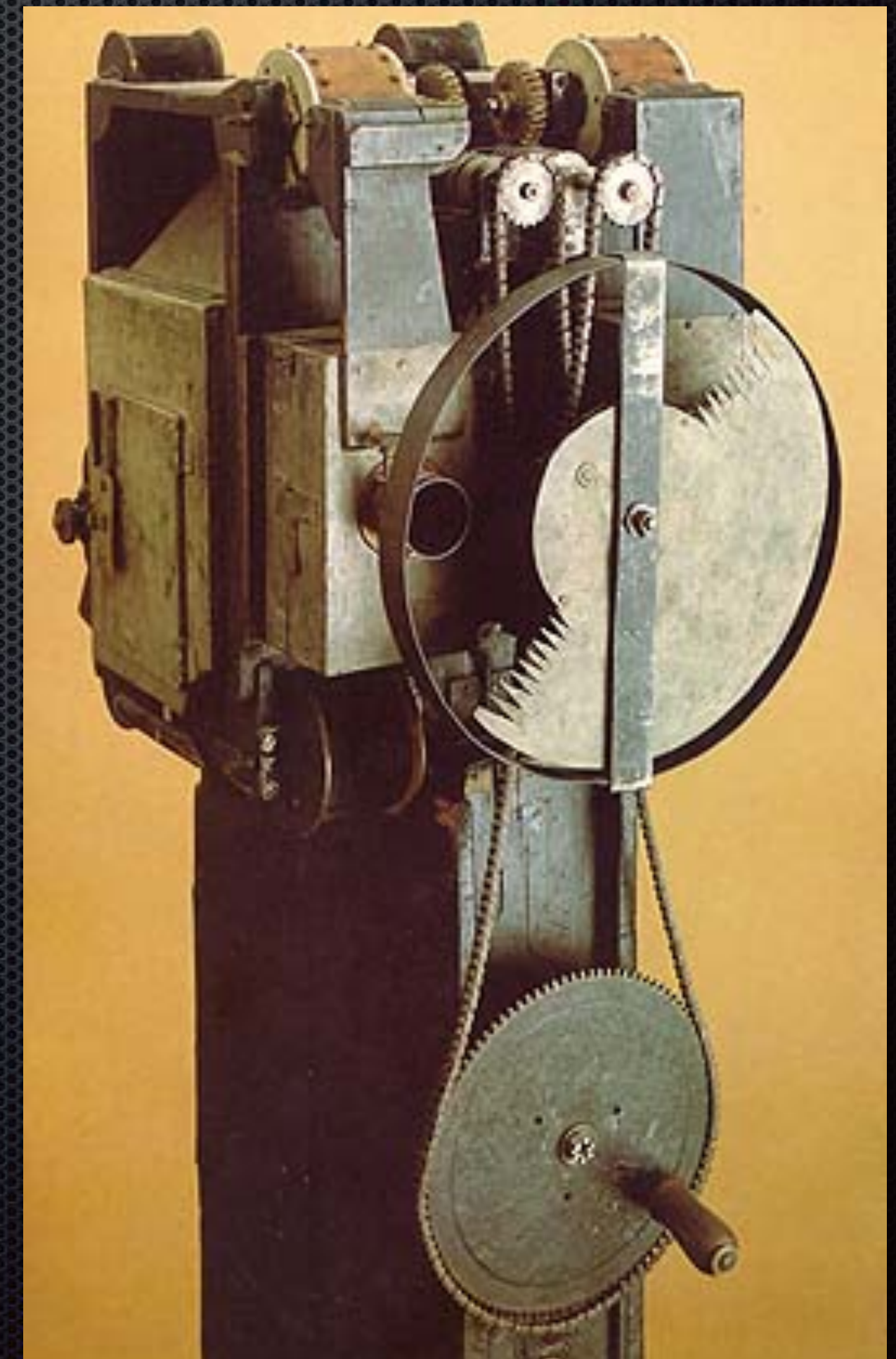

Kinematographie

Varieté Vorstellung
Jahrmarktsattraktionen
Dokumentationen
Abgefilmtes Theater
Reisedokus

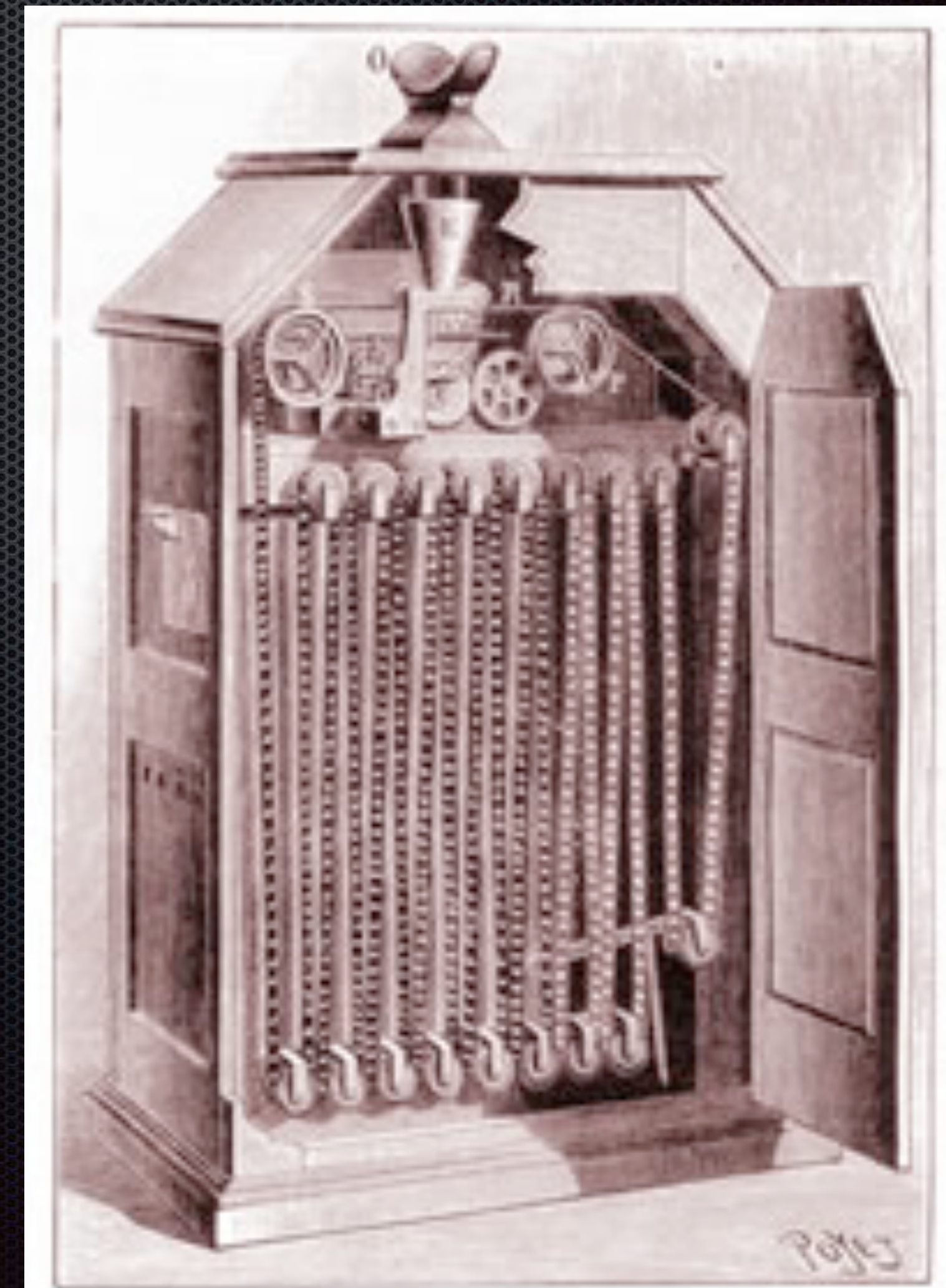

Kinematographie

“Die Reise zum Mond” (1902)
von Georeg Méliès

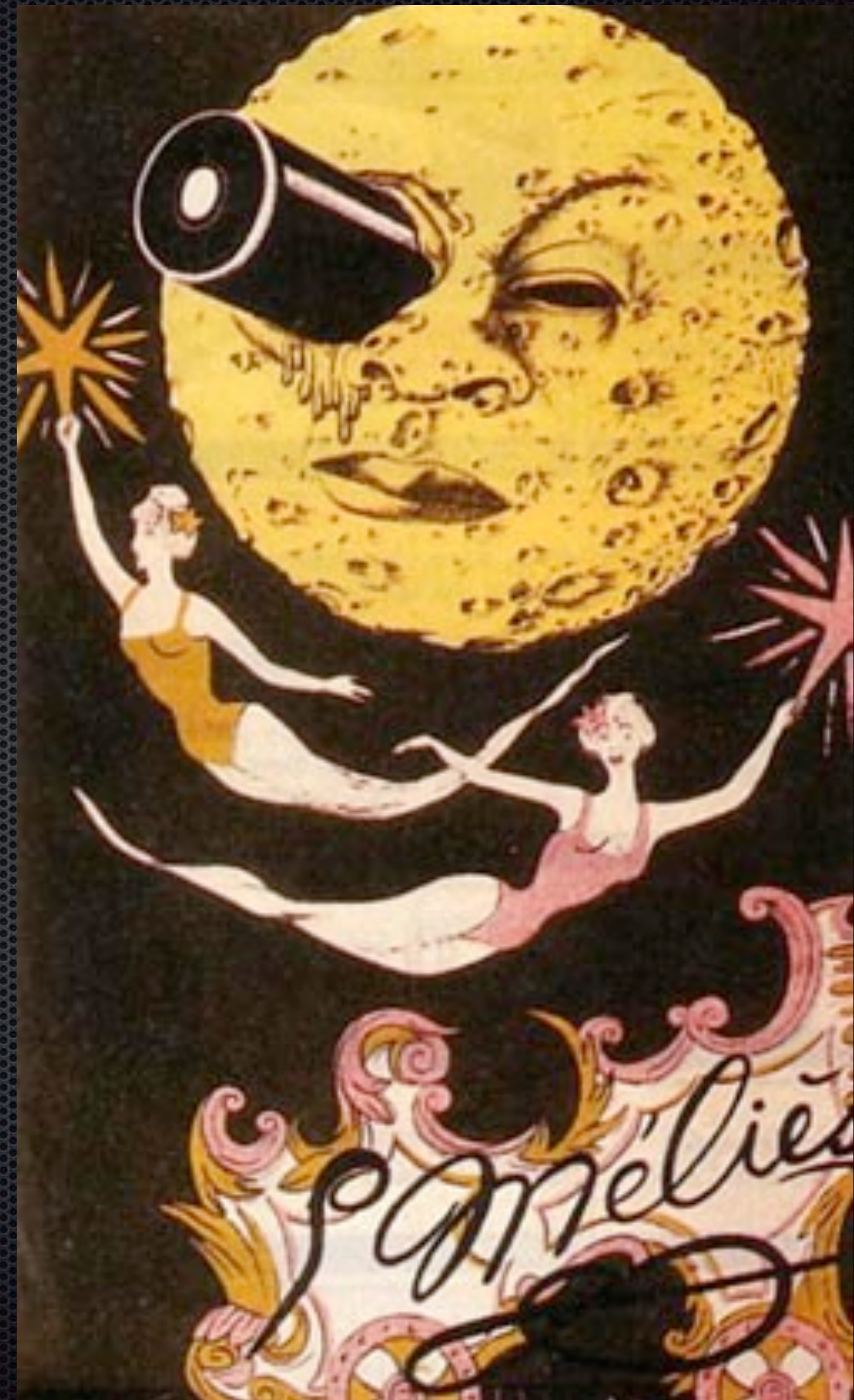

“Die Reise zum
Mond” (1902)
von Georeg
Méliès

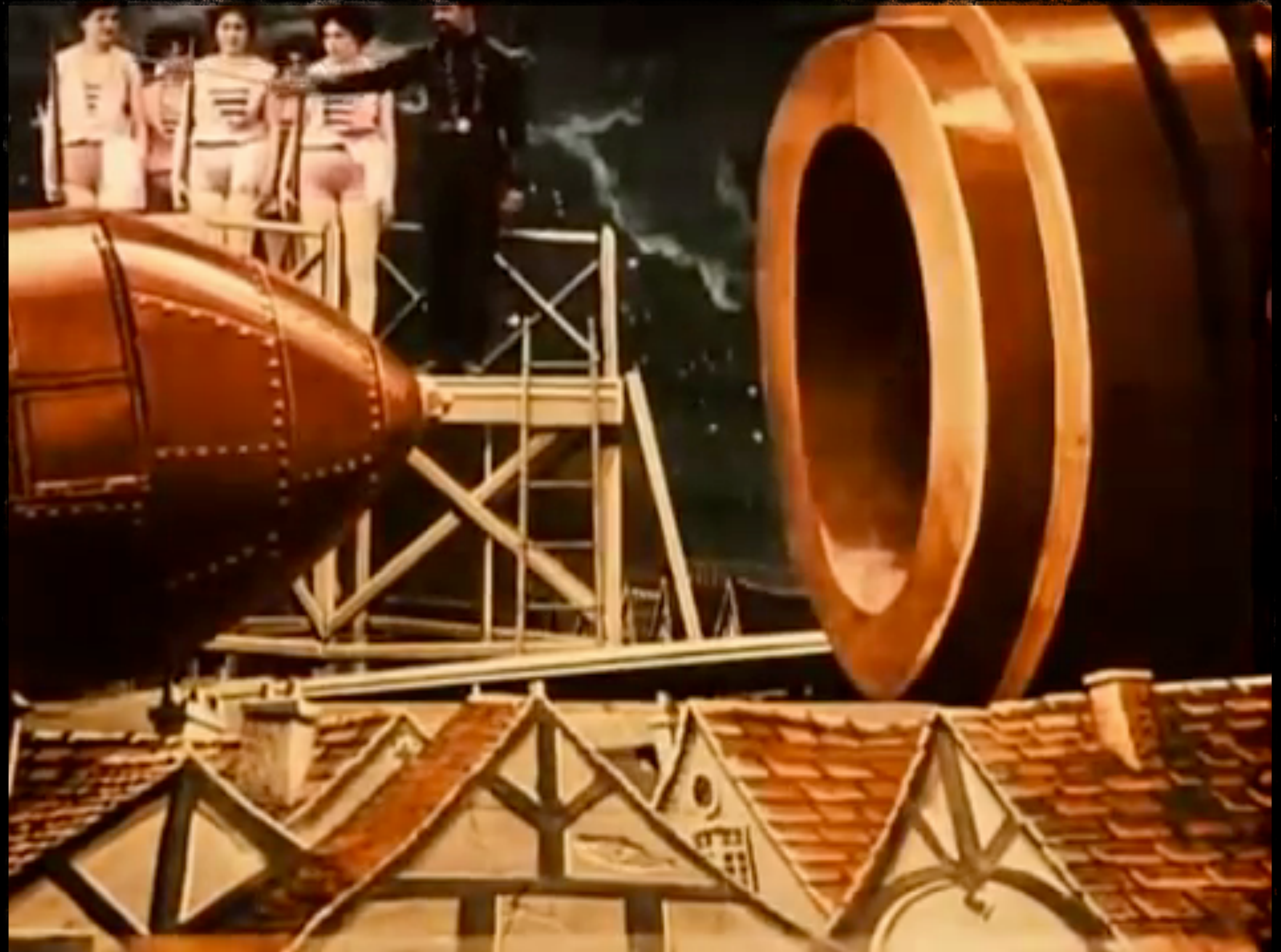



3sat HD thementag



Clara Eleonore Stinnes • Schwarzweiß-Filme • 1927

Kamera – analog

35mm Film

ab...	Filmformat
1894	70mm
1894	35mm
1923	16mm
1932	8mm
1965	Super8

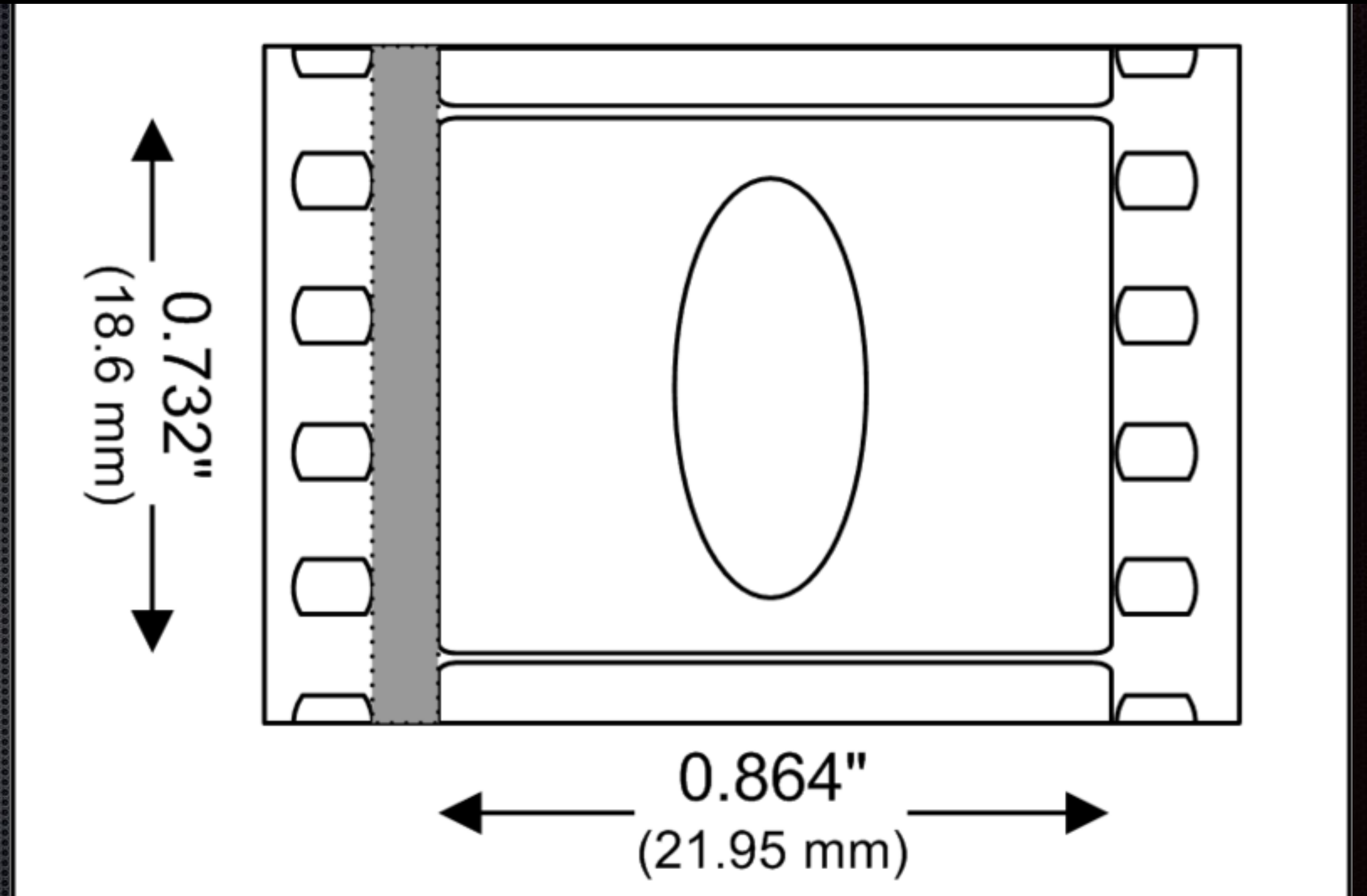

Beispiel: Cinemascope 4 perf 35 mm

1900

1800

1900

2000

2017

Kamera (35mm Film)

The cinématographe
Lumière

Oskar Messter

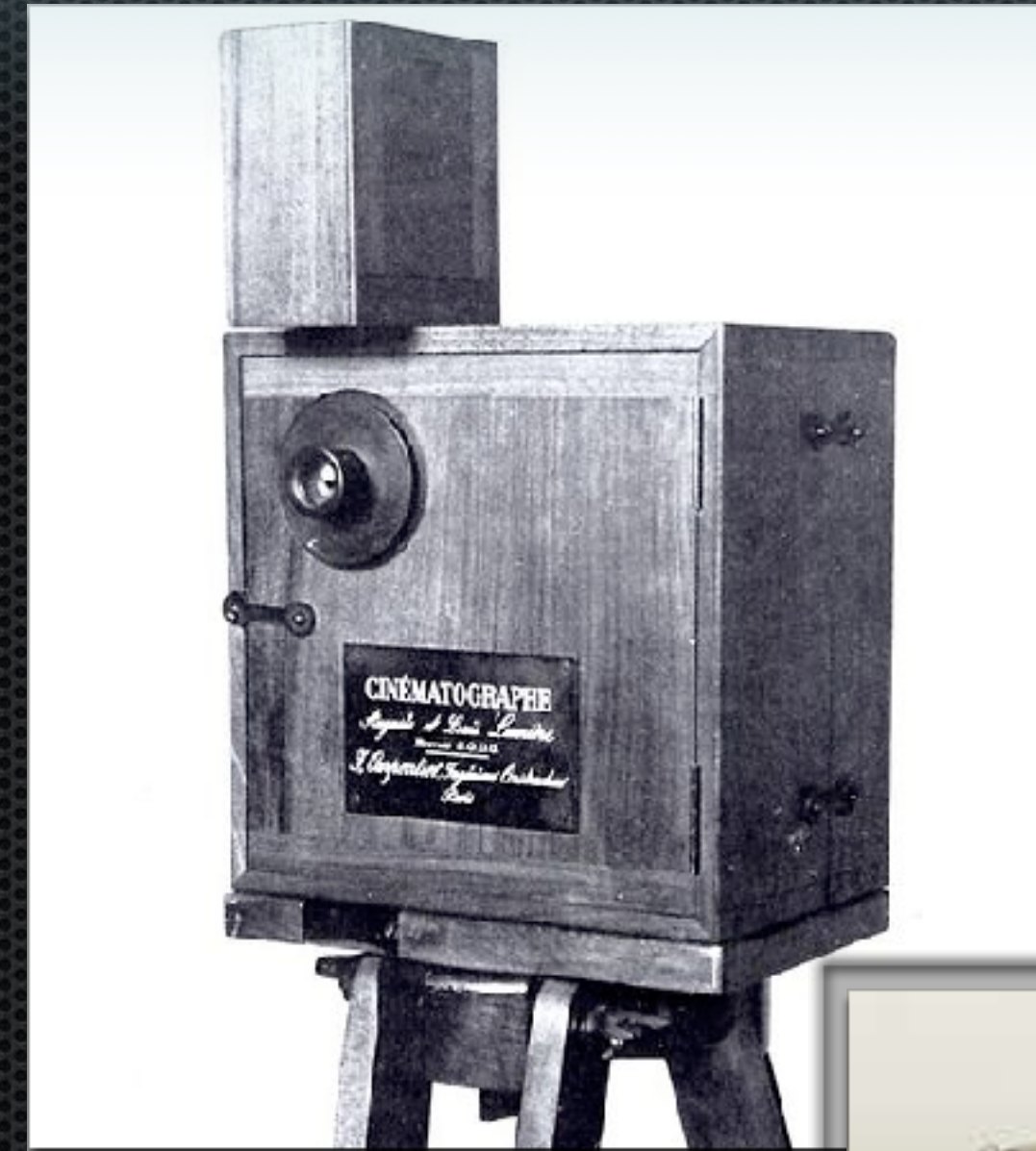

1970

1800

1900

2000

2017

Kino/35mm Film

Stanley Kubrick

2001: A Space Odyssey

hier: ARRI 35IIC (35 mm Film)

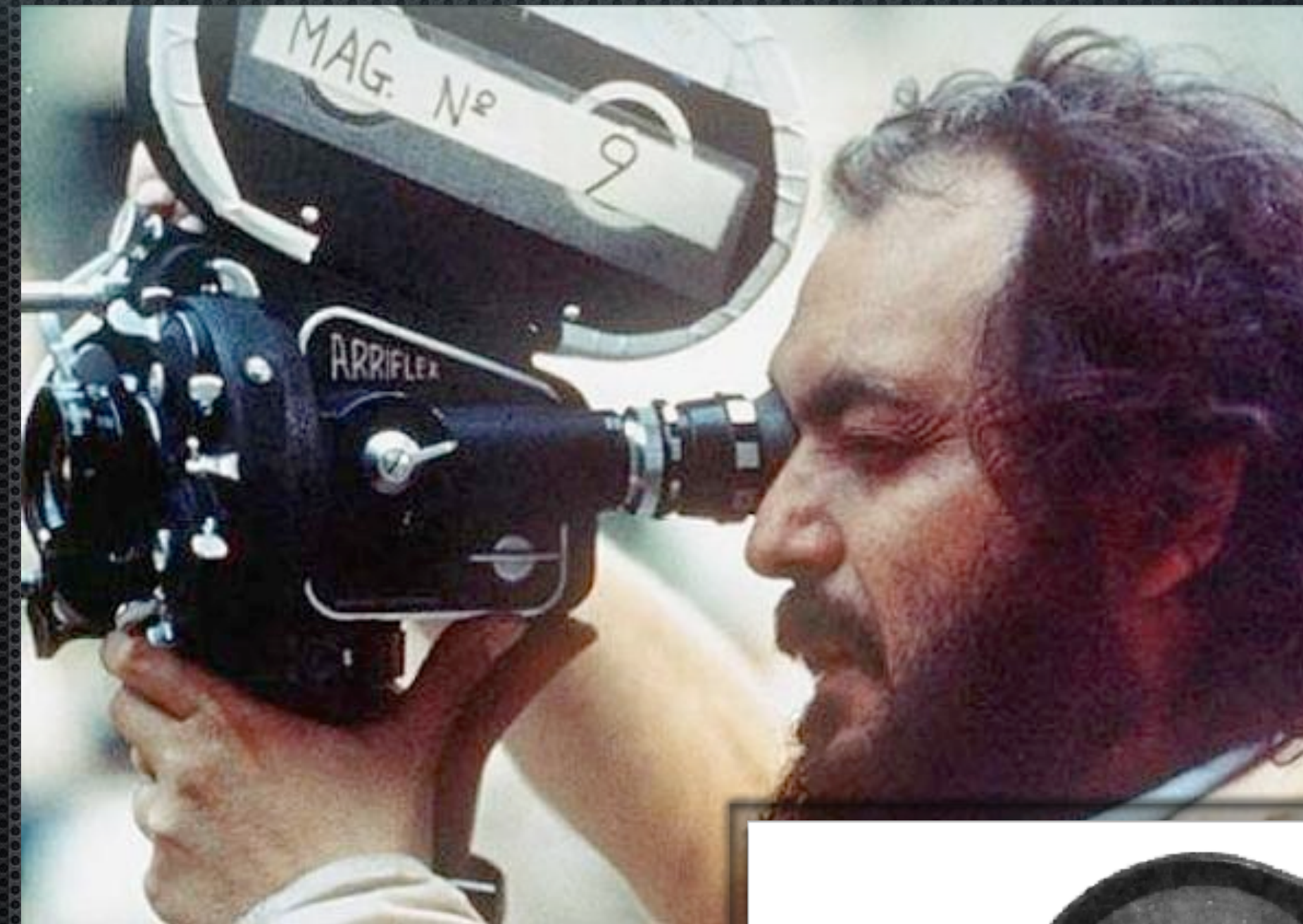

2004

1800

1900

2000

2017

35mm Film

ARRIFLEX 535 B

Kino

Werbung

TV-Serien

z.B. "Dr. House" – bis 2009

– jetzt digital

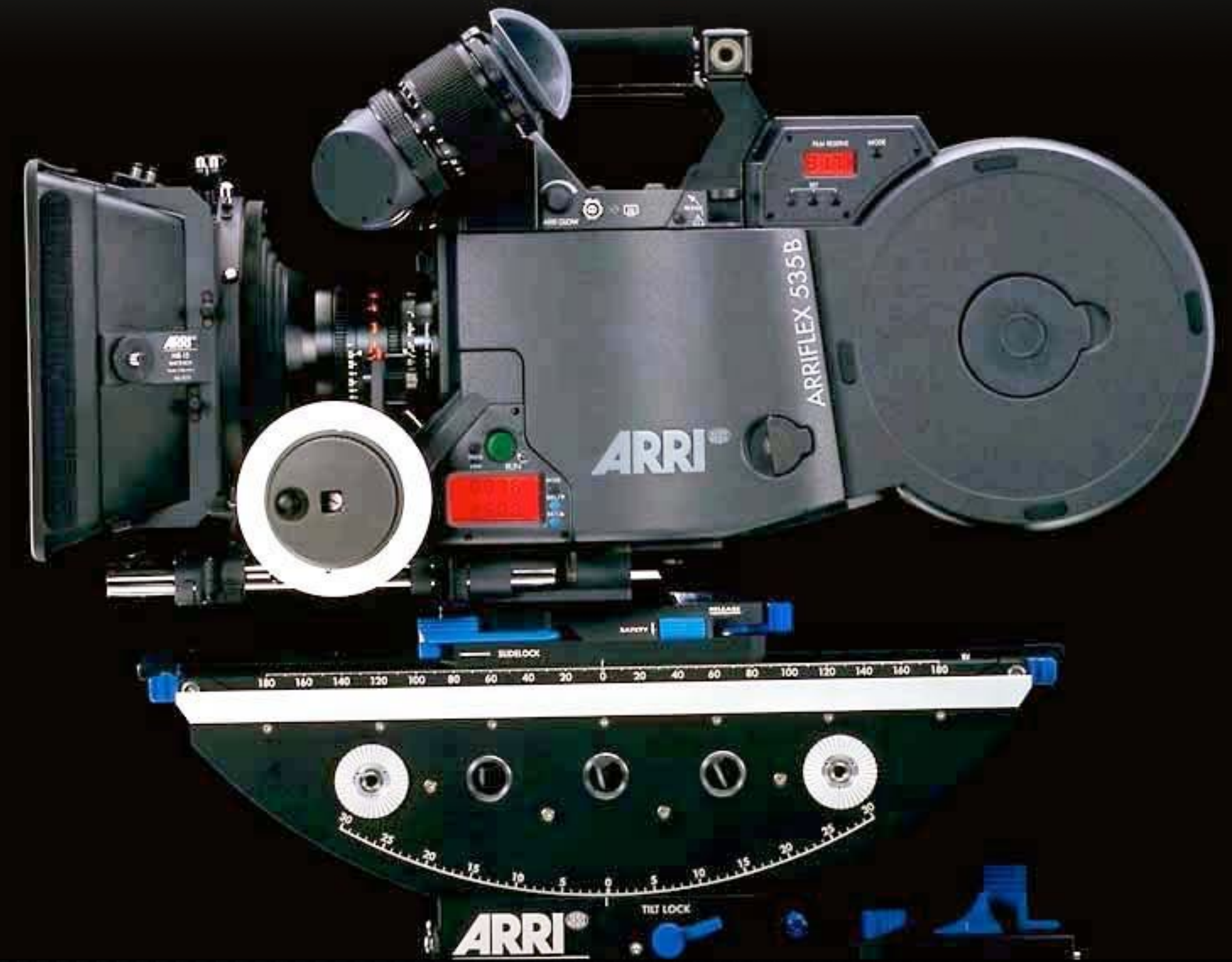

2006

1800

1900

2000

2017

16mm Film

ARRIFLEX 416

Dokumentarfilm
Dokumentationen
Tier- und Natur-Filme
Tatort



1999

1800

1900

2000

2017

16mm Film

Aaton A-Minima

Dokumentarfilm

Dokumentationen

Tier- und Natur-Filme

und “**Moonrise Kingdom**” (2012), Wes Anderson



1970

1800

1900

2000

2017

Super8

- ★ Filmgeschichte
- ★ Dramaturgie
- ★ Ästhetik



2018

2017

2000

1900

1800

Super8

2018 stellt Kodak
eine neue Super8 Kamera vor.
Und produziert weiterhin auch
Super8 Filme!



2012

1800

1900

2000

2017

Kamera (35mm Film)

2012

Die großen Kamerahersteller (ARRI, Panavision, Aaton) erklären, dass sie keine neuen Film-Kameras mehr herstellen.

Kodak – einziger Hersteller von Filmmaterial – produziert nach wie vor.

Auch für das Herstellen von Vorführkopien wird noch Filmmaterial verwendet, auch wenn z.B. in Deutschland die meisten Kino über einen digitalen Projektor verfügen.

Digital Cinema – Video



35mm
Filmkamera







“Tangerine”
directed by Sean Baker
Sundance Film Festival 2015
Gedreht auf einem iPhone 5s





2017 dreht Sean Baker
“The Florida Project”
auf einer
Panavision
Panaflex Millennium XL2 auf
35mm Film

und
Digital mit iPhone 6s und Arri
Axexa Mini

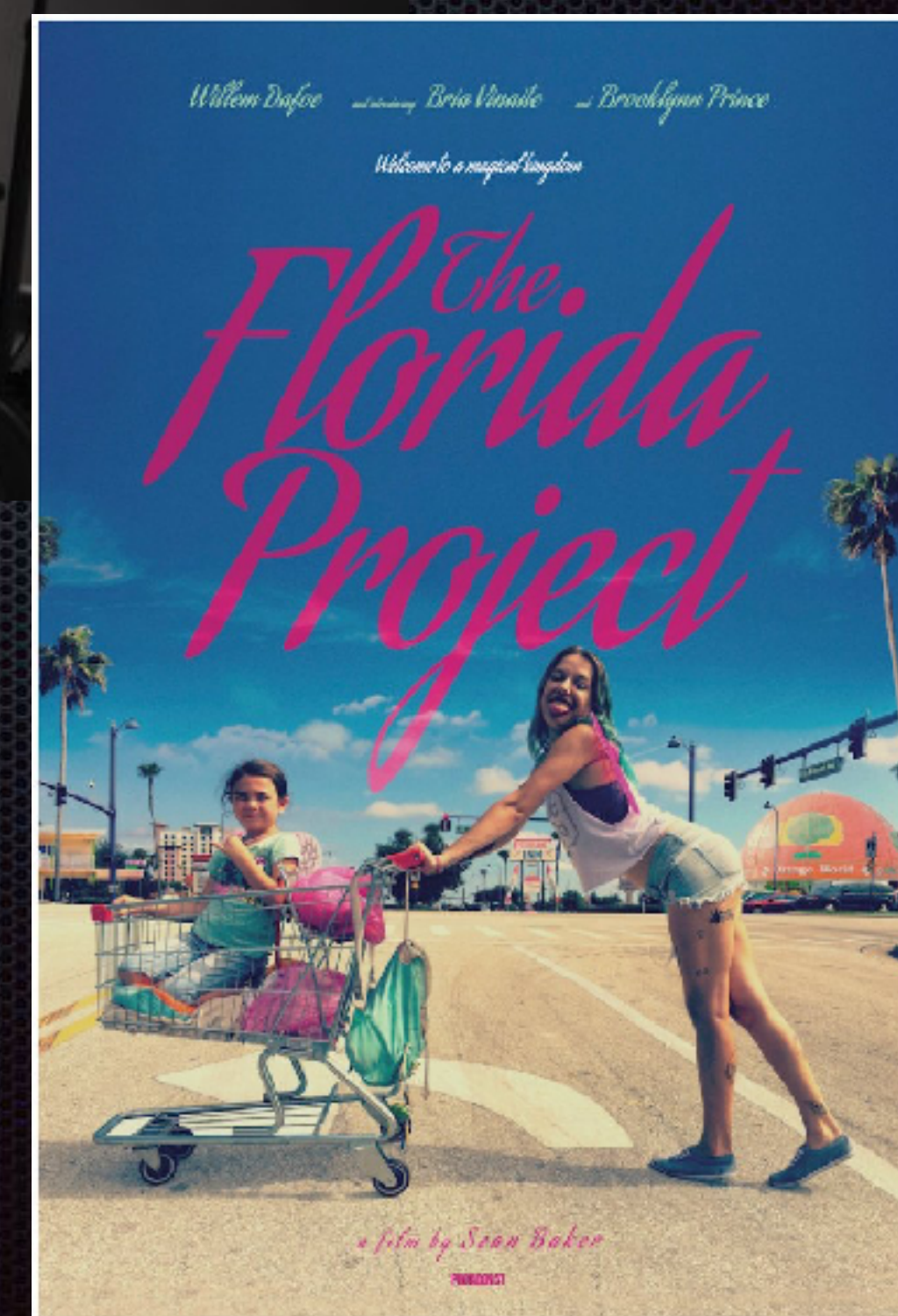

Video
analog bis digital

1956

1800

1900

2000

2017

Ampex VR 1000
Kamera RCA TK-40/41

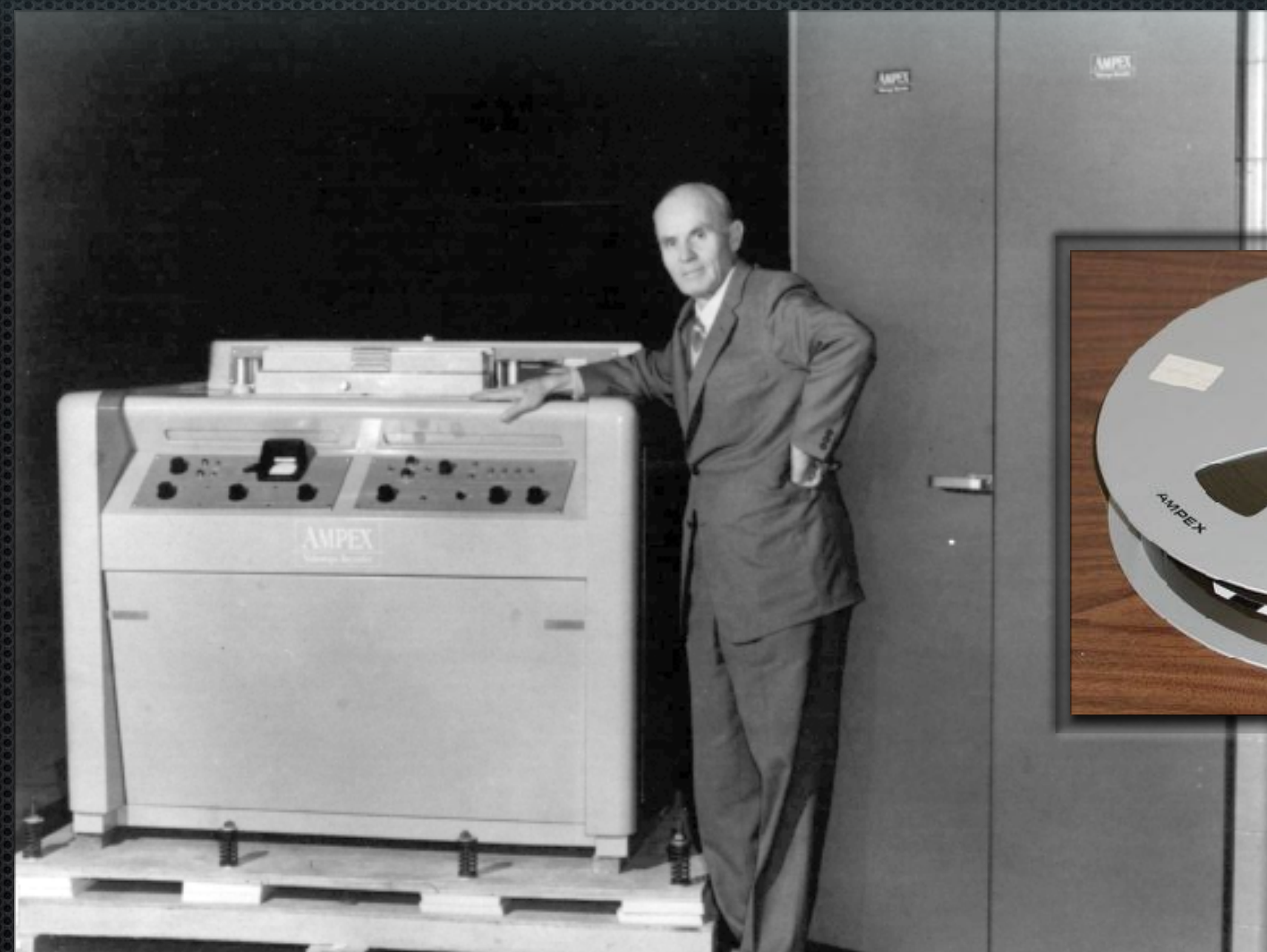

2" Magnet-Bandmaschine
(2" \approx 5 cm)

1986

1800

1900

2000

2017

Video Analog - Aufzeichnung TAPE



Betacam SP für den
Broadcast-Bereich



1967

1800

1900

2000

2017

1/2" Bandmaschine

“portapak” von SONY



1977

1800

1900

2000

2017

1/2" Kasette

VHS System



1984

1984

The image features the year '1984' in large, white, three-dimensional block letters. The numbers are positioned in the center of the frame. The background is a blurred outdoor scene, possibly a park or a street, with trees and utility poles visible. The lighting is soft, suggesting a late afternoon or early morning setting. The overall aesthetic is that of a vintage graphic or a title card for a video or film.

1995

1800

1900

2000

2017

Video Digital - Aufzeichnung DV TAPE



DV-Camcorder von SONY



DV-Camcorder von Panasonic

Hohe Qualität der Aufzeichnung - (fast) sendetauglich fürs Fernsehen

1995

1800

1900

2000

2017

Video Digital – Aufzeichnung TAPE



DVCPRO/DVCAM für den Broadcast-Bereich

2004

1800

1900

2000

2017

Video Digital – Aufzeichnung SSD

HPX 2100

Panasonic

HVX200



P2 Karte (Festspeicher)

2014

1800

1900

2000

2017

Video Digital - 4K



Pick Up > Shoot

AMIRA 

The new documentary-style camera

Amira

2015

1800

1900

2000

2017

Blackmagicdesign Pocket Camera



2015

1800

1900

2000

2017

TV-Reportage mit BM Pocket Camera



Kamera – Digital Kino und TV/Serien

2018

2017

2000

1900

1800

Kamera (Digital)

ARRI Alexa

4,5 K Full Frame Sensor



ab 2004

1800

1900

2000

2017

Kamera (Digital)

Panavision
Millennium DXL2
(Red Monstro 8K Sensor)



Batman vs. Superman

- Arri Alexa XT
- Arriflex 416
- Arriflex 435, Panavision C- and E-Series Lenses
- Canon EOS 5D
- GoPro HD Hero 4
- IMAX MKIII, Zeiss Lenses
- IMAX MSM 9802, Hasselblad Lenses
- Panavision Panaflex Millennium XL2, Panavision Primo, C-, E-Series, ATZ and AWZ2 Lenses
- Panavision Panaflex System 65 Studio, Panavision System 65 Lenses





Need for Speed (2014)

[Edit](#)

Technical Specifications

Showing all 10 technical specifications

Runtime 2 hr 12 min (132 min)

Camera

Arri Alexa M, Cooke S4 Lenses

Arri Alexa Plus, Cooke S4, Angenieux Optimo and Canon EF Cinema Lenses

Black Magic Cinema Camera

Canon EOS C500, Cooke S4, Angenieux Optimo and Canon EF Cinema Lenses

Canon EOS-1D C, Zeiss ZE and Canon EF Cinema Lenses

GoPro HD Hero 3

Laboratory	DeLuxe, Hollywood (CA), USA
Film Length	3,581 m (7 reels)
Negative Format	Codex
Cinematographic Process	ARRIRAW (2.8K) (source format) Canon Cinema RAW (4K) (source format) Digital Intermediate (2K) (master format)
Printed Film Format	35 mm (anamorphic) (Fuji Eterna-CP 3514DI) D-Cinema (also 3-D version)



CANON C500
COOKE 100mm
ISO 850



ARRI Alexa



Canon C500



GoPro Hero4

Kamera – Digital

Semi bis Professionell

Kamera (Digital) 2018

Panasonic
AC 130
AVCHD Format



Kamera (Digital) 2015

Canon 5D

Full Frame Sensor
“Filmlook”

H.264 / Quicktime



Kamera (Digital) 2017

Sony Alpha 7 R III

Full Frame Sensor
“Filmlook”
H.264 / Quicktime



Kamera (Digital) 2017

Canon C200

Super 35 Sensor
4K Aufzeichnung



Kamera (Digital) 2015

Sony FS 5

Super 35 Sensor
4K Aufzeichnung



Kamera (Digital) ab 2006

GoPro Hero 7

kompakt + outdoor
4K Aufzeichnung





Kamera (Digital) 2015

360° Video

FREEDOM360 MOUNT
mit
sechs HERO4



Kamera (Digital) 2018

GoPro Fusion 360°

kompakt + outdoor
5.2K Aufzeichnung





Lion Whisperer | Racing Extinction (360 Video)

<https://www.youtube.com/watch?v=GdP1NnbtAc>

to be continued...